

BETTER PUMP SOLUTIONS



Index / Inhaltsverzeichnis

Page / Seite

Pd pumps

PEEK flat-valve technology
PEEK Flachventiltechnik

electric operated
elektrisch betrieben

4 - 5

non-metallic
nichtmetallisch

6 - 13

double acting
doppeltwirkend

14 - 17

standard
Standard

18 - 23

AOPD pumps

Flat- or ball valve technology
Flach- oder Kugelventiltechnik

non-metallic
nichtmetallisch

24 - 33

AODD pumps

Ball valve technology
Kugelventiltechnik

polypropylene
Polypropylene

34 - 39

aluminium
Aluminium

40 - 49

stainless steel
Edelstahl

50 - 53

Explanation of materials / Erläuterung der Materialien

Wetted parts / Flüssigkeitsberührte Teile

A	Aluminium	High grade casted aluminum AISi12Mn according to CSN 424331
PP	Polypropylene	Similar to PE but can tolerate a higher temperature (aca, 100 ° C), PP is highly resistant to chemicals. At higher temperatures (above 60 ° C), the oxidation is accelerated in particular when dealing with metals such as copper and manganese. PP is widely used in chemical industries. Tecno-Matic is adding 30% glass fiber to the mixture, this ensures flexibility and maintains dimension stability.
S	Stainless Steel	High grade casted stainless steel AISi 316
PEEK	Polyether ether ketone	This high performance engineering plastic is extremely resistant to all kinds of adverse or critical operating conditions. The material is resistant to high constant temperature while keeping excellent dimensional stability and will still retains the chemical resistance. It is applied in the chemical industry as high-quality, mechanically stressed parts.
POMC	Polyacetal	Material looks a lot like nylon. Polyacetal is, however, stiffer and tougher especially at higher temperatures. Because the material does not absorb moisture, the specifications as well as the chemical resistance are better. Low coefficient of friction in comparison to metals and other plastics. Highly abrasive resistant.
PTFE	Polytetrafluoroethylene	Very good chemical properties. Suitable for temperature to + 240 ° C. Low friction coefficient. PTFE can not be glued. Its hydrophobic: neither water nor water-containing substances wet PTFE. It is used for reactive and corrosive chemicals. Gaskets, bearings, pump parts, etc. produced from PTFE.
PVC	Polyvinyl chloride	Good chemical resistance, good welding and gluing. The applications we can find in the chemical industry, laboratories, piping in the galvanic and electrical industry. It is less wear-resistant. PVC is the third-most widely produced synthetic plastic polymer.

Elastomers

X	Santoprene vulcanized (TPV)	Is part of the thermoplastic elastomer (TPE) family of polymers, combining the characteristics of vulcanized rubber with the processing properties of thermoplastics. Purchased directly from Exxon Mobil – inventor of this material.
NBR	Nitrile rubber	Also known as Buna-N. This form of synthetic rubber is generally resistant to oil, fuel, and other chemicals. The more nitrile within the polymer, the higher the resistance to oils but the lower the flexibility of the material. By our special diaphragm shape the most ideal mix can be produced. Nitrile rubber is in generally resistant to aliphatic hydrocarbons.
TW	Teflon Vulcanized	Strong NBR layer vulcanized together with PTFE layer to create a flexible and stable performance of the diaphragm, but which still maintain the excellent PTFE chemical resistant of liquids.

- electric operated -

pd pumps®



Test report included!
Prüfbericht inklusive!



- Capacity 0,5 -120 l/min
- 1¼" connections
- Max. Pressure 3 bar
- Motor 230/400 V - 50 Hz - 0,75 Kw
- Including! Frequency inverter
- Connection 1- ¼"
- High suction (8,5 mtr)
- Viscosity up to 2000 cp
- Max. sizes solid parts in liquid 4 mm
- Low noise (65 dBa)
- Full machined POM-C pump body
- Standard PTFE / NBR backup Diaphragms
- Suitable for abrasive liquids
- Very compact design
- Operating in each position
- Dry running capability
- Low maintenance costs

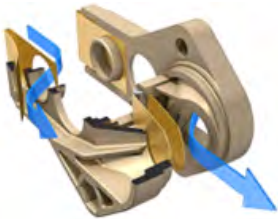

Equipped with **PEEK flat-valve technology**, means high stroke frequency

Ausgeführt mit PEEK Flachventiltechnik d.h. schnelle Hubfrequenz

- Kapazität 0,5 -120 l/Min.
- 1¼" Anschlüsse
- Max. Druck 3 bar
- Motor 230/400 V - 50 Hz - 0,75 Kw
- Frequenzumrichter Inklusive !
- Anschluss 1- ¼"
- Hohe Saugleistung (8,5 m)
- Viskosität bis zu 2000 cP
- Feststoffe bis 4 mm
- Äusserst leise (65 dBa)
- Machinell bearbeitetes POM-C Gehäuse
- Standard PTFE / NBR Stützmembrane
- Beständig gegen ab abrasive Flüssigkeiten
- Kompaktes Design
- Funktioniert in jeder Positionslage
- Trockenlauf geeignet
- Niedrige Wartungskosten

PD pumps

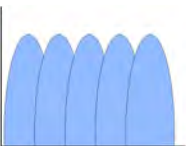

High stroke frequency, means low liquid pulsation
Durch schnelle Hubfrequenz geringe Pulsation der Flüssigkeit

AODD pumps



low stroke frequency, means high liquid pulsation
langsame Hubfrequenz hohe Pulsation der Flüssigkeit

APPLICATIONS

CHEMICALS • SOLVENTS • PLATING • ACIDS • OILS • INKS • GLUES • ALKALIES • ENAMEL
POLYESTER PAINT • WASTE WATER • COOLING LIQUIDS • FOAMS • HYDRAULIC OILS

Flowchart / Flussdiagramm

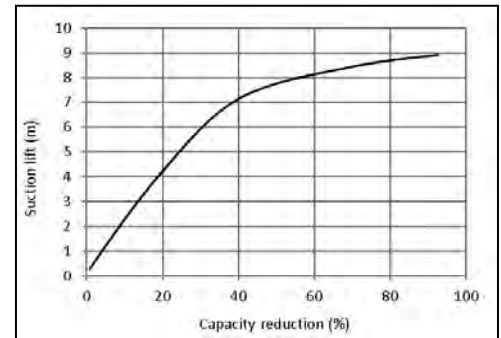
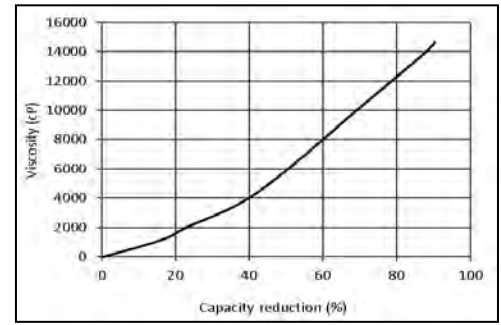
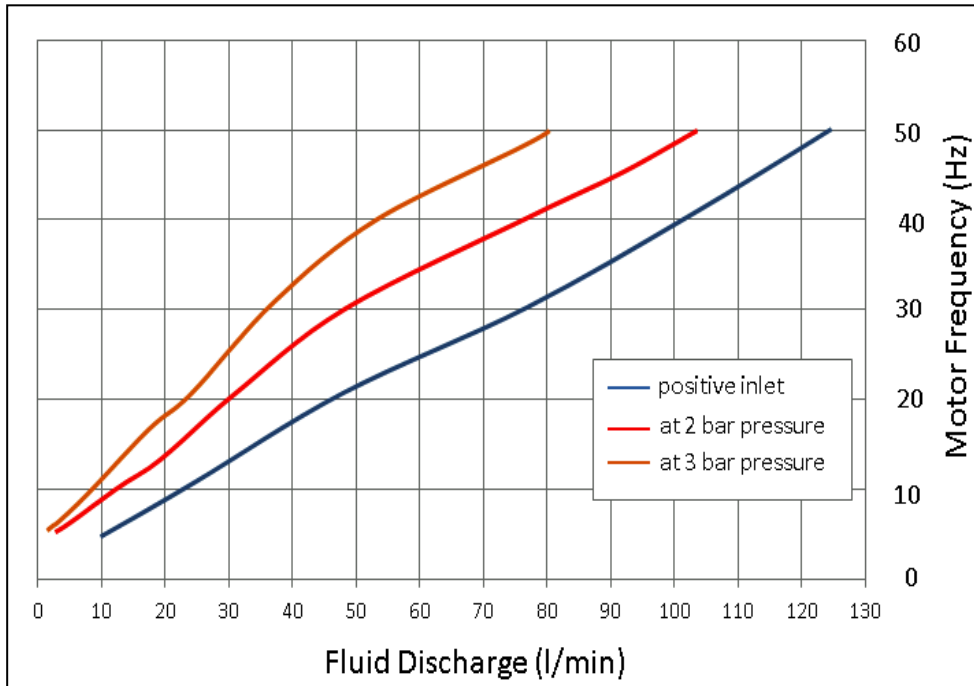

Available types - Verfügbare Typen

ATEX Version on request
ATEX Version auf Anfrage

Type	liquid wetted parts – Flüssigkeitsberührte Teile
EDF120-POM-TW	POM-C / PTFE / SST (316) / PEEK
EDF120-PVC-TW	PVC / PTFE / SST (316) / PEEK
EDF120-PP-TW	PP / PTFE / SST (316) / PEEK
EDF120-SST-TW	SST (316) / PTFE / PEEK
EDF120-PE-TW	PE / PTFE / SST (316) / PEEK
EDF120-PTFE-TW	PTFE / PEEK / SST (316)

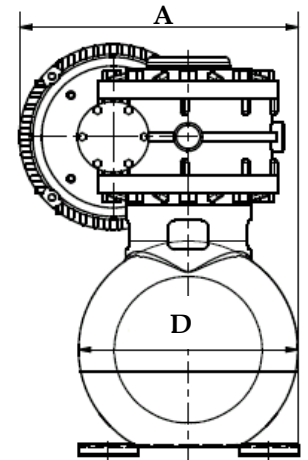
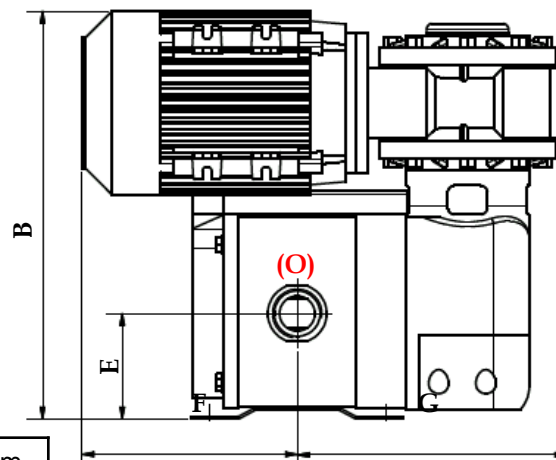
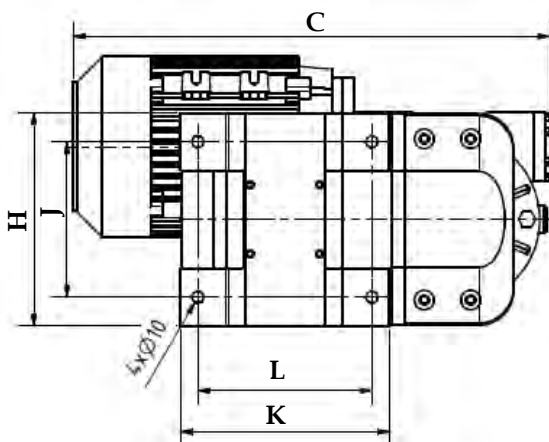

A	235 mm	G	230 mm
B	350 mm	H	185 mm
C	410 mm	J	135 mm
D	185 mm	K	180 mm
E	90 mm	L	150 mm
F	185 mm	In - outlet	(O) 1-1/4"

Current	3-Phase 230 / 400V
Frequency	50 Hz
Motor Power	0,75 Kw
Rpm	2730
Safety Class	IP55

Max. weight: 25 - 40 Kg



Test report included!
Prüfbericht inklusive!



- Capacity 1 – 40 l/min
- 1/2" connections
- High suction lift (9,4 Mtr)
- Viscosity up to 3000 cP
- Max. sizes solid parts in liquid 3 mm
- Equipped with PEEK flat-valves
- Low noise (65 dBa) & low vibration
- Full machined POM-C, PTFE or PVC bodies
- Standard PTFE / NBR backup Diaphragms
- Only few liquid wetted parts
- New POMC high speed air-motor design
- Excellent abrasive liquid resistance
- Up to 35% lower air-consumption !
- Very compact design
- With ATEX certification
- Operating in each position
- Dry running capability
- Low maintenance costs

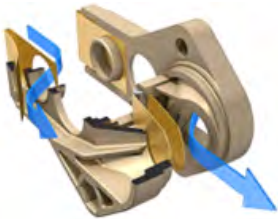

Equipped with
PEEK flat-valve technology,
means high stroke frequency

Ausgeführt mit
PEEK Flachventiltechnik
d.h. schnelle Hubfrequenz

- Kapazität 1 - 40 l/Min.
- 1/2" Anschlüsse
- Hohe Saugleistung (9,4 m)
- Viskosität bis zu 3000 cP
- Feststoffe bis 3 mm
- Ausgeführt mit PEEK-Flachventilen
- Äusserst leise (65 dBa) und geringe Pulsation
- Pumpengehäuse: POM-C, PTFE oder PVC
- Standard PTFE / NBR Stützmembrane
- Nur wenig medienberührte Teile
- Neuer POMC High-Speed Luftmotor
- Beständig gegen abrasive Flüssigkeiten
- Bis zu 35% weniger Luftverbrauch
- Kompaktes Design
- Mit ATEX-Zertifizierung
- Funktioniert in jeder Positionslage
- Trockenlauf geeignet
- Niedrige Wartungskosten

PD pumps

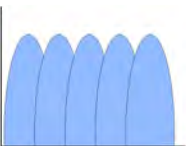

High stroke frequency,
means **low liquid pulsation**
Durch schnelle Hubfrequenz
geringe Pulsation der Flüssigkeit

AODD pumps



low stroke frequency,
means **high liquid pulsation**
langsame Hubfrequenz
hohe Pulsation der Flüssigkeit

APPLICATIONS

CHEMICALS • SOLVENTS • PLATING • ACIDS • OILS • INKS • GLUES • ALKALIES • ENAMEL
POLYESTER PAINT • WASTE WATER • COOLING LIQUIDS • FOAMS • HYDRAULIC OILS

Flowchart / Flussdiagramm

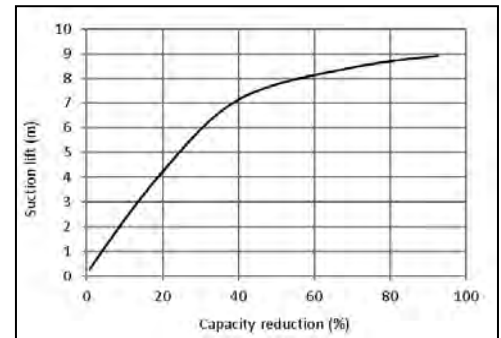
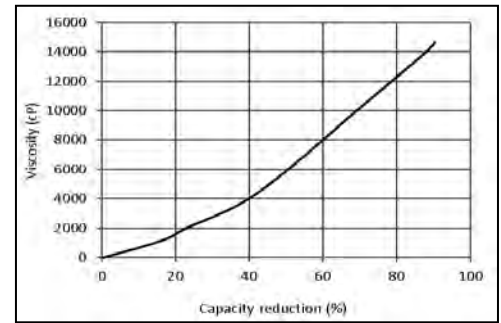
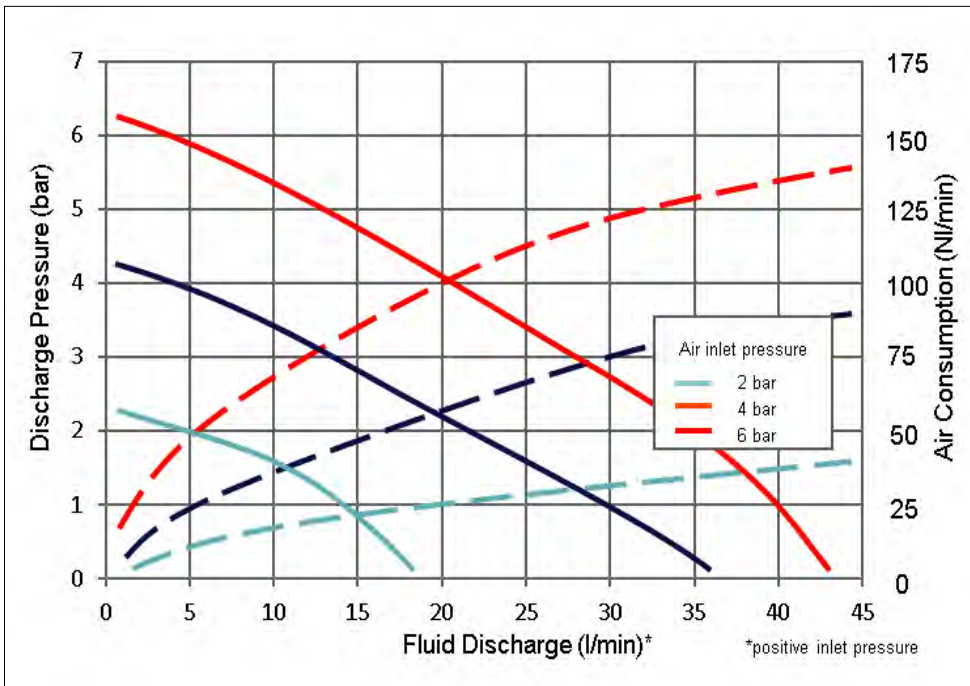

Available types - Verfügbare Typen

Type	liquid wetted parts – Flüssigkeitsberührte Teile
ADF40-POM-TW	POM-C / PTFE / SST (316) / PEEK
ADF40-POM-TW-C	POM-C / PTFE / PEEK / Ceramic
ADF40-PVC-TW	PVC / PTFE / SST (316) / PEEK
ADF40-PVC-TW-C	PVC / PTFE / PEEK / Ceramic
ADF40-PTFE-TW	PTFE / SST (316) / PEEK
ADF40-PTFE-TW-C	PTFE / PEEK / Ceramic
ADF40-SST-TW	SST (316) / PTFE / PEEK
ADF40-SST-TW-C	SST (316) / PTFE / PEEK / Ceramic

Max. weight: 3 Kg

A	65 mm	K	12 mm
B	65 mm	L	145 mm
C	100 mm	R	15 mm
D	100 mm	S	120 mm
E	15 mm	W	140 mm
H	145 mm	in-outlet	1/2"

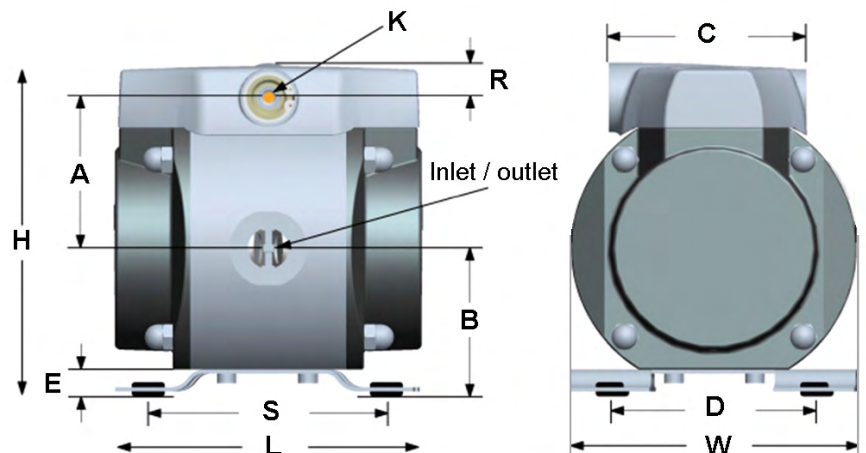



Test report included!
Prüfbericht inklusive!



- Capacity 1 – 70 l/min
- 3/4" connections
- High suction lift (9,4 mtr)
- Viscosity up to 3000 cP
- Max. sizes solid parts in liquid 4 mm
- Equipped with PEEK flat-valves
- Low noise (65 dBa) & low vibration
- Full machined POM-C, PTFE or PVC bodies
- Standard PTFE / NBR backup Diaphragms
- Only few liquid wetted parts
- New POMC high speed air-motor design
- Suitable for abrasive liquids
- Up to 35% lower air-consumption !
- Very compact design
- With ATEX certification
- Operating in each position
- Dry running capability
- Low maintenance costs



Equipped with
PEEK flat-valve technology,
means high stroke frequency

Ausgeführt mit
PEEK Flachventiltechnik
d.h. schnelle Hubfrequenz

- Kapazität 1 - 70 l/Min
- 3/4" Anschlüsse
- Hohe Saugleistung (9,4 m)
- Viskosität bis zu 3000 cP
- Feststoffe bis 4 mm
- Ausgeführt mit PEEK-Flachventilen
- Äusserst leise (65 dBa) und geringe Pulsation
- Pumpengehäuse: POM-C, PTFE oder PVC
- Standard PTFE / NBR Stützmembrane
- Nur wenig medienberührte Teile
- Neuer POMC High-Speed Luftmotor
- Beständig gegen abrasive Flüssigkeiten
- Bis zu 35% weniger Luftverbrauch
- Kompaktes Design
- Mit ATEX-Zertifizierung
- Funktioniert in jeder Positionslage
- Trockenlauf geeignet
- Niedrige Wartungskosten

PD pumps

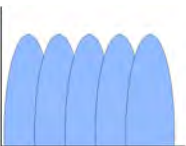

High stroke frequency,
means **low liquid pulsation**
Durch schnelle Hubfrequenz
geringe Pulsation der Flüssigkeit

AODD pumps



low stroke frequency,
means **high liquid pulsation**
langsame Hubfrequenz
hohe Pulsation der Flüssigkeit

APPLICATIONS

CHEMICALS • SOLVENTS • PLATING • ACIDS • OILS • INKS • GLUES • ALKALIES • ENAMEL
POLYESTER PAINT • WASTE WATER • COOLING LIQUIDS • FOAMS • HYDRAULIC OILS

Flowchart / Flussdiagramm

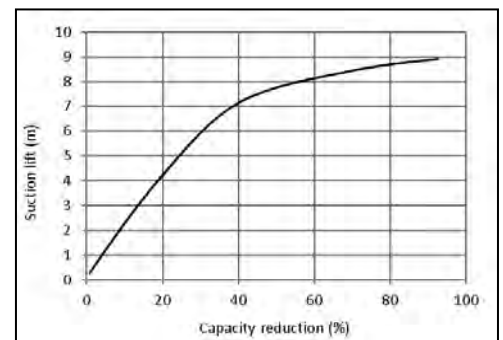
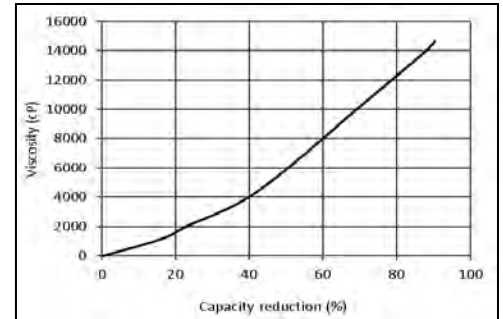
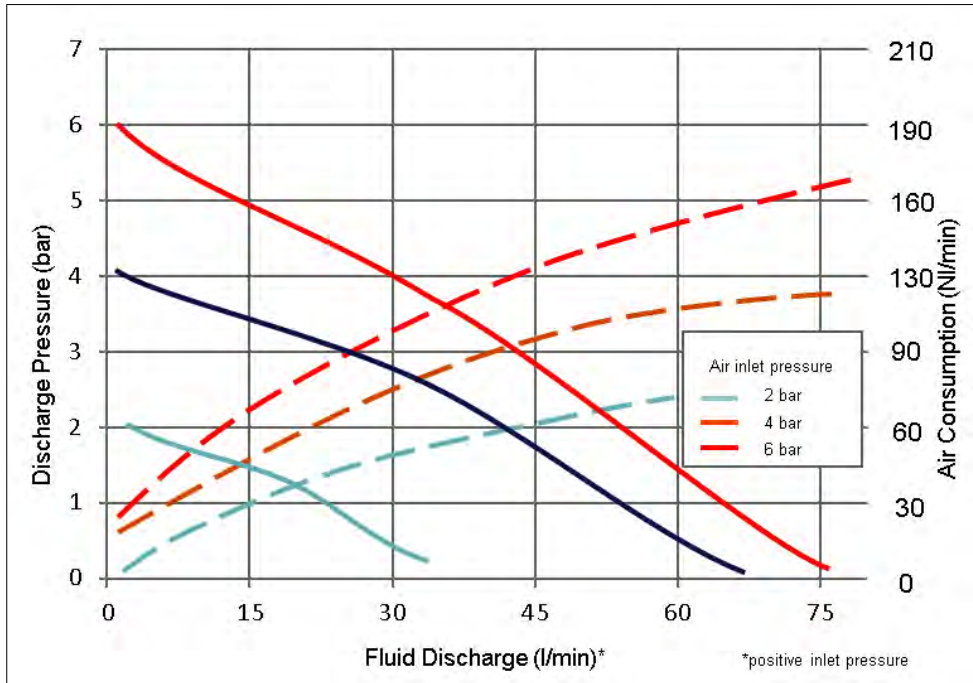

Available types - Verfügbare Typen

Type	liquid wetted parts – Flüssigkeitsberührte Teile
ADF70-POM-TW	POM-C / PTFE / SST (316) / PEEK
ADF70-POM-TW-C	POM-C / PTFE / PEEK / Ceramic
ADF70-PVC-TW	PVC / PTFE / SST (316) / PEEK
ADF70-PVC-TW-C	PVC / PTFE / PEEK / Ceramic
ADF70-PTFE-TW	PTFE / SST (316) / PEEK
ADF70-PTFE-TW-C	PTFE / PEEK / Ceramic

Max. weight: 5 Kg

A	75 mm	K	12 mm
B	75 mm	L	145 mm
C	100 mm	R	15 mm
D	100 mm	S	120 mm
E	15 mm	W	140 mm
H	165 mm	in-outlet	3/4"

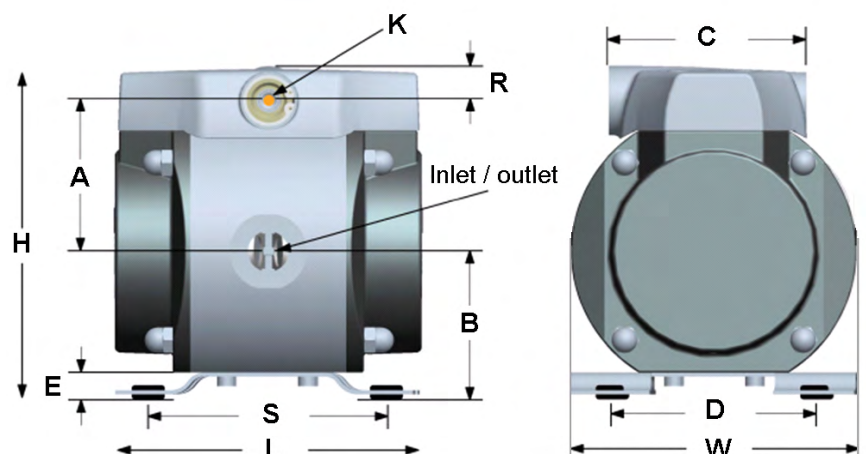



Test report included!
Prüfbericht inklusive!



- Capacity 5 – 125 l/min
- 1¼" connections
- High suction vacuum (9,5 mtr)
- Viscosity up to 3000 cP
- Max. sizes solid parts in liquid 5 mm
- Equipped with PEEK flat-valves
- Low noise (68 dBA) & vibration
- Full machined POM-C, PTFE or PVC bodies
- Standard PTFE / NBR backup Diaphragms
- Only few liquid wetted parts
- New POMC high speed air-motor design
- Suitable for abrasive liquids
- Up to 35% lower air-consumption !
- Very compact design
- With ATEX certification
- Operating in each position
- Dry running capability
- Low maintenance costs



Equipped with
PEEK flat-valve technology,
means high stroke frequency

Ausgeführt mit
PEEK Flachventiltechnik
d.h. schnelle Hubfrequenz

- Kapazität 5 - 125 l/Min.
- 1¼" Anschlüsse
- Hohe Saugleistung (9,5 m)
- Viskosität bis zu 3000 cP
- Feststoffe bis 5 mm
- Ausgeführt mit PEEK-Flachventilen
- Äusserst leise (68 dBA) und geringe Pulsation
- Pumpengehäuse: POM-C, PTFE oder PVC
- Standard PTFE / NBR Stützmembrane
- Nur wenige medienberührte Teile
- Neuer POMC High-Speed Luftmotor
- Standardbeschichtung Epoxy oder POM-C
- Beständig gegen abrasive Flüssigkeiten
- Bis zu 35% weniger Luftverbrauch
- Kompaktes Design
- Mit ATEX-Zertifizierung
- Funktioniert in jeder Positionslage
- Trockenlauf geeignet
- Niedrige Wartungskosten

PD pumps

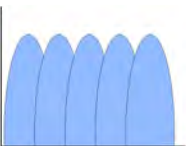

High stroke frequency,
means low liquid pulsation
Durch schnelle Hubfrequenz
geringe Pulsation der Flüssigkeit

AODD pumps



low stroke frequency,
means high liquid pulsation
langsame Hubfrequenz
hohe Pulsation der Flüssigkeit

APPLICATIONS

CHEMICALS • SOLVENTS • PLATING • ACIDS • OILS • INKS • GLUES • ALKALIES • ENAMEL
POLYESTER PAINT • WASTE WATER • COOLING LIQUIDS • FOAMS • HYDRAULIC OILS

Flowchart / Flussdiagramm

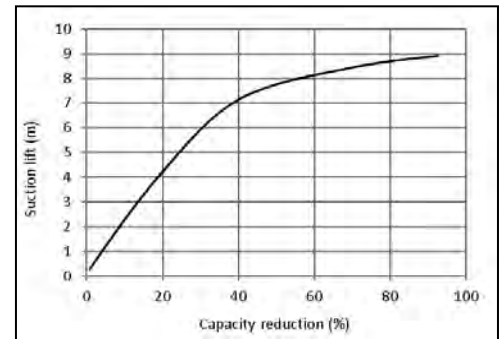
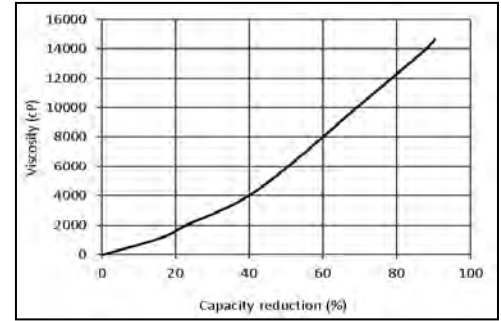
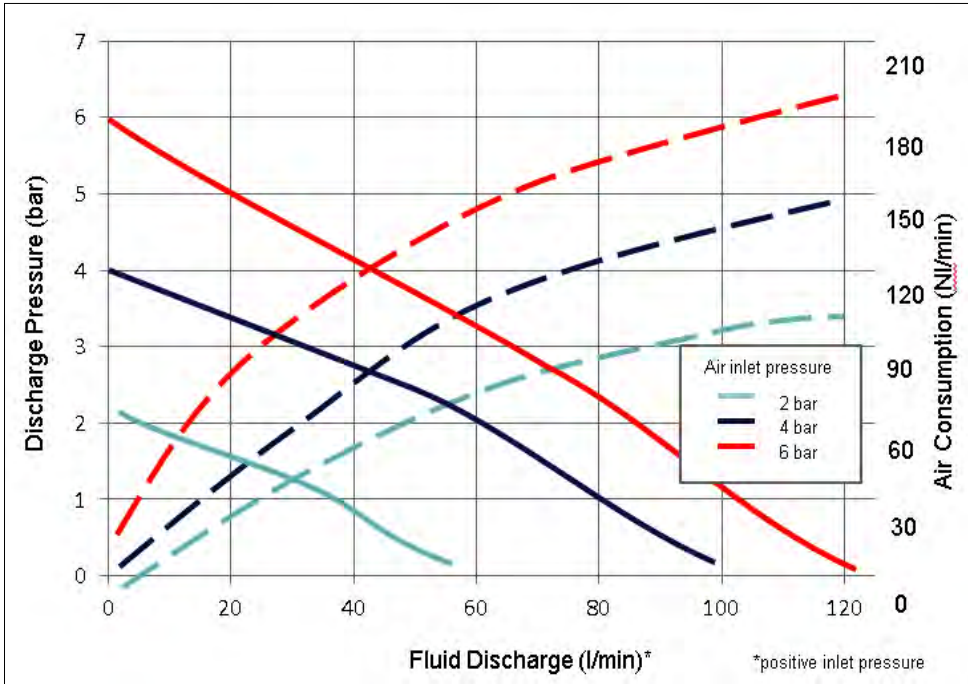

Available types - Verfügbare Typen

Type	liquid wetted parts – Flüssigkeitsberührte Teile
ADF125-POM-TW	POM-C / PTFE / SST (316) / PEEK
ADF125-POM-TW-C	POM-C / PTFE / PEEK / Ceramic
ADF125-PVC-TW	PVC / PTFE / SST (316) / PEEK
ADF125-PVC-TW-C	PVC / PTFE / PEEK / Ceramic
ADF125-PTFE-TW	PTFE / SST (316) / PEEK
ADF125-PTFE-TW-C	PTFE / PEEK / Ceramic

Max. weight: 7 Kg

A	100 mm	K	12 mm
B	100 mm	L	180 mm
C	100 mm	R	15 mm
D	135 mm	S	150 mm
E	15 mm	W	185 mm
H	210 mm	in-outlet	1-1/4"

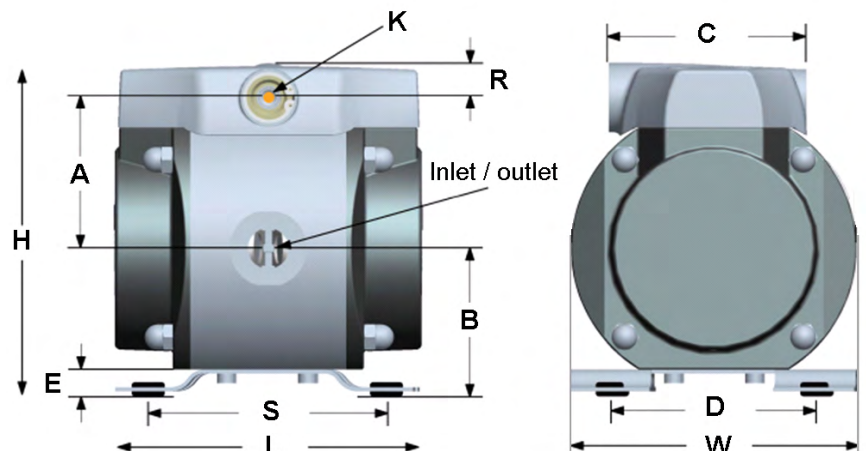



Test report included!
Prüfbericht inklusive!



- Capacity 5 - 250 l/min
- 2" connections
- High suction vacuum (9,5 mtr)
- Double acting (low liquid pulsation!)
- Pressure up to 7 bar
- Viscosity up to 3000 cP
- Max. sizes solid parts in liquid 5 mm
- Low noise (68 dBa) & vibration
- Machined POM-C, PTFE or PVC bodies
- Standard PTFE / NBR backup Diaphragms
- Only few liquid wetted parts
- Suitable for abrasive liquids
- Significant low air-consumption !
- Very compact design
- With ATEX certification
- Operating in each position
- Dry running capability
- Low maintenance costs

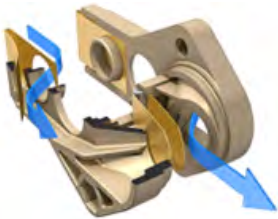

Equipped with
PEEK flat-valve technology,
means high stroke frequency

Ausgeführt mit
PEEK Flachventiltechnik
d.h. schnelle Hubfrequenz

- Kapazität 5 - 250 l/Min.
- 2" Anschlüsse
- Hohe Saugleistung (9,5 m)
- Doppeltwirkend (geringes Pulsieren ausreichend)
- Druckluft bis zu 7 bar
- Viskosität bis zu 3000 cP
- Feststoffe bis 5 mm
- Niedriger Geräuschpegel (68 dBa) und Pumpvibrationen
- Pumpengehäuse: POM-C, PTFE oder PVC
- Standard PTFE / NBR Stützmembrane
- Nur wenige medienberührte Teile
- Beständig gegen abrasive Flüssigkeiten
- Luftverbrauch erheblich geringer!
- Kompaktes Design
- Mit ATEX-Zertifizierung
- Funktioniert in jeder Positionslage
- Trockenlauf geeignet
- Niedrige Wartungskosten

PD pumps

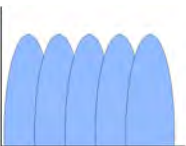

High stroke frequency,
means **low liquid pulsation**
Durch schnelle Hubfrequenz
geringe Pulsation der Flüssigkeit

AODD pumps



low stroke frequency,
means **high liquid pulsation**
langsame Hubfrequenz
hohe Pulsation der Flüssigkeit

APPLICATIONS

CHEMICALS • SOLVENTS • PLATING • ACIDS • OILS • INKS • GLUES • ALKALIES • ENAMEL
POLYESTER PAINT • WASTE WATER • COOLING LIQUIDS • FOAMS • HYDRAULIC OILS

Flowchart / Flussdiagramm

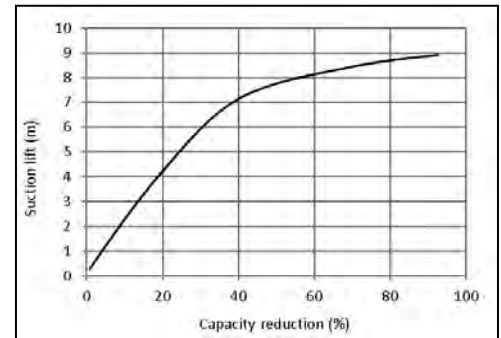
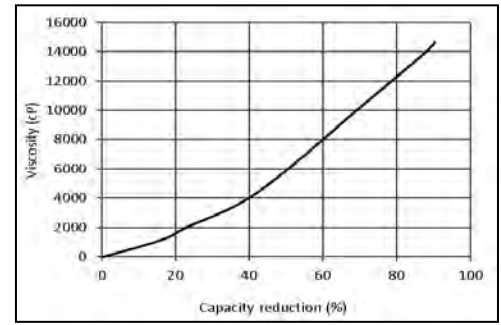
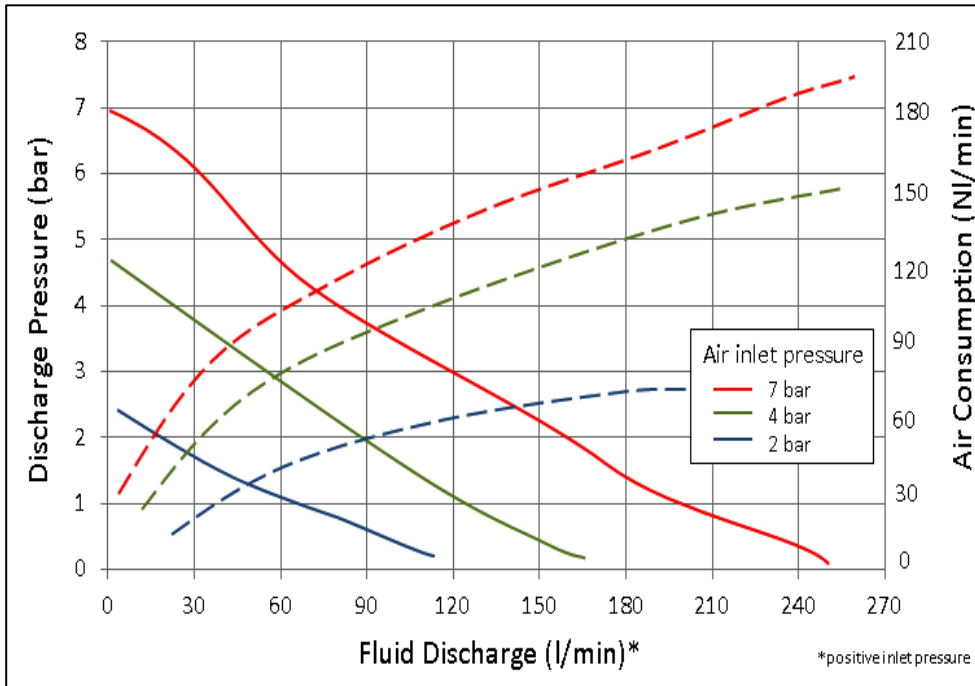

Available types - Verfügbare Typen

Type	liquid wetted parts – Flüssigkeitsberührte Teile
ADF250-POM-TW	POM-C / PTFE / SST (316) / PEEK
ADF250-POM-TW-C	POM-C / PTFE / PEEK / Ceramic
ADF250-PVC-TW	PVC / PTFE / SST (316) / PEEK
ADF250-PVC-TW-C	PVC / PTFE / PEEK / Ceramic
ADF250-PTFE-TW	PTFE / SST (316) / PEEK
ADF250-PTFE-TW-C	PTFE / PEEK / Ceramic

Max. weight: 15 Kg

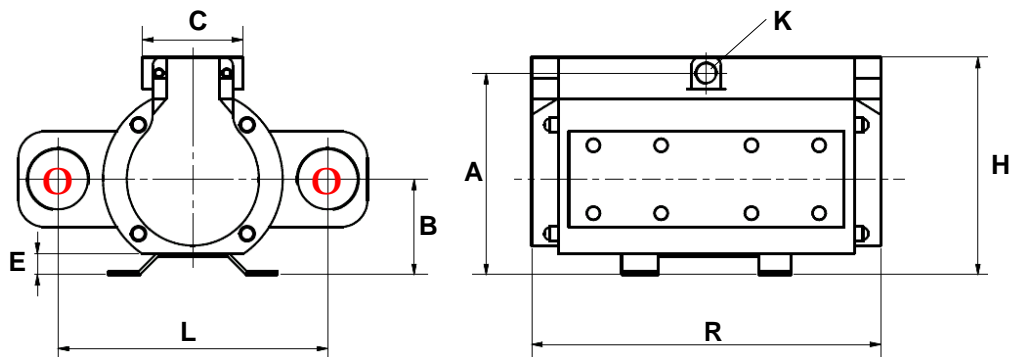

A	190 mm	K (airhose)	∅12 mm
B	90 mm	L	255 mm
C	95 mm	R	330 mm
D	145 mm	S	135 mm
E	15 mm	W	330 mm
H	205 mm	in-outlets	(∅) 2"

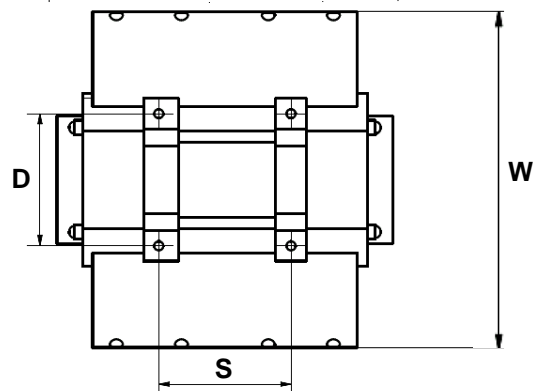

- double acting - **pd pumps**®



Test report included!
Prüfbericht inklusive!



- Capacity max. 2 x – 40 l/min
- Separate operating pump chambers
- 1/2" connections
- High suction vacuum (9,5 mtr)
- Double acting (low liquid pulsation!)
- Pressure up to 7 bar
- Viscosity up to 3000 cP
- Max. sizes solid parts in liquid 3 mm
- Low noise (68 dBA) & vibration
- Machined POM-C, PTFE or PVC bodies
- Standard PTFE / NBR backup Diaphragms
- Only few liquid wetted parts
- Suitable for abrasive liquids
- Significant low air-consumption !
- Very compact design
- With ATEX certification
- Operating in each position
- Dry running capability
- Low maintenance costs

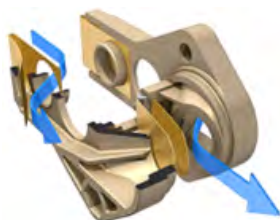

Equipped with
PEEK flat-valve technology,
means high stroke frequency

Ausgeführt mit
PEEK Flachventiltechnik
d.h. schnelle Hubfrequenz

- Kapazität max. 2 X 40 l/Min.
- Pumpkammern separat in Betrieb
- 1/2" Anschlüsse
- Hohe Saugleistung (9,5 m)
- Doppeltwirkend (geringes Pulsieren ausreichend)
- Druckluft bis zu 7 bar
- Viskosität bis zu 3000 cP
- Feststoffe bis 3 mm
- Niedriger Geräuschpegel (68 dBA) und Pumpvibrationen
- Pumpengehäuse: POM-C, PTFE oder PVC
- Standard PTFE / NBR Stützmembrane
- Nur wenige medienberührte Teile
- Beständig gegen abrasive Flüssigkeiten
- Luftverbrauch erheblich geringer!
- Kompaktes Design
- Mit ATEX-Zertifizierung
- Funktioniert in jeder Positionslage
- Trockenlauf geeignet
- Niedrige Wartungskosten

PD pumps



High stroke frequency,
means **low liquid pulsation**
Durch schnelle Hubfrequenz
geringe Pulsation der Flüssigkeit

AODD pumps



low stroke frequency,
means **high liquid pulsation**
langsame Hubfrequenz
hohe Pulsation der Flüssigkeit

APPLICATIONS

CHEMICALS • SOLVENTS • PLATING • ACIDS • OILS • INKS • GLUES • ALKALIES • ENAMEL
POLYESTER PAINT • WASTE WATER • COOLING LIQUIDS • FOAMS • HYDRAULIC OILS

Flowchart / Flussdiagramm

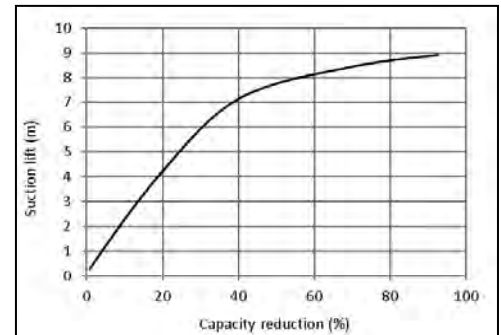
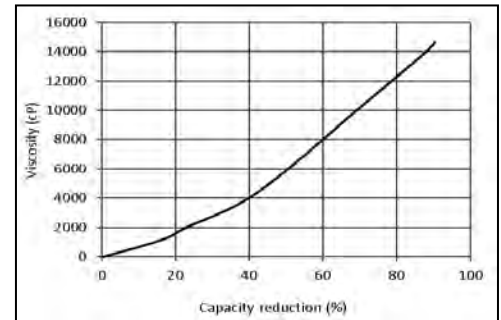
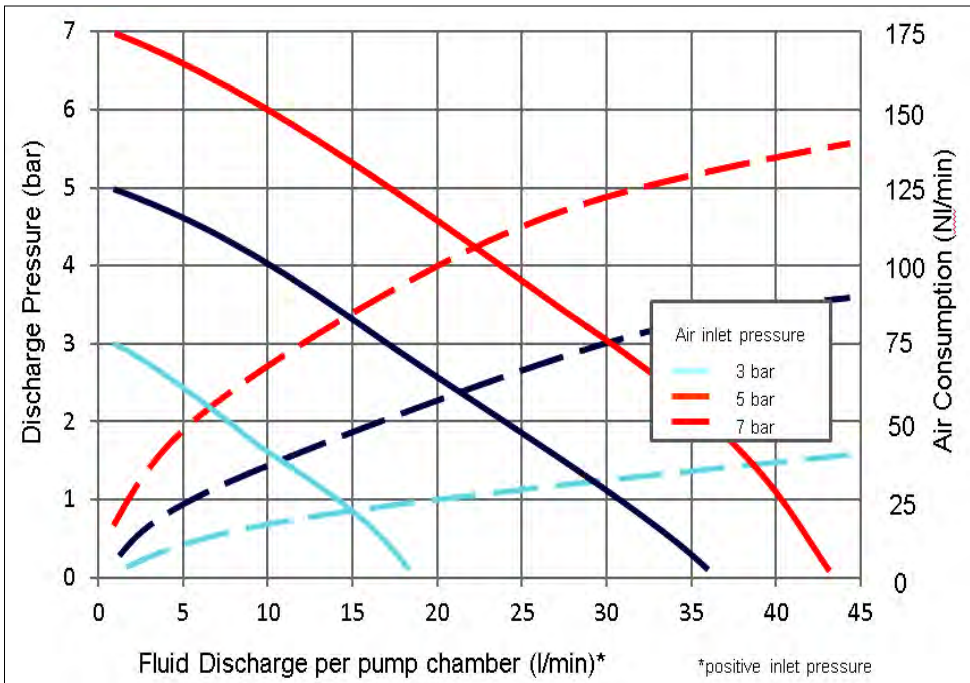

Available types - Verfügbare Typen

Type	liquid wetted parts – Flüssigkeitsberührte Teile
ADF80-POM-TW	POM-C / PTFE / SST (316) / PEEK
ADF80-POM-TW-C	POM-C / PTFE / PEEK / Ceramic
ADF80-PVC-TW	PVC / PTFE / SST (316) / PEEK
ADF80-PVC-TW-C	PVC / PTFE / PEEK / Ceramic
ADF80-PTFE-TW	PTFE / SST (316) / PEEK
ADF80-PTFE-TW-C	PTFE / PEEK / Ceramic

Max. weight: 7 Kg

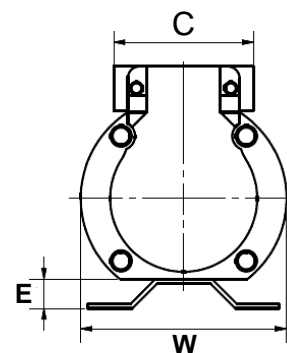
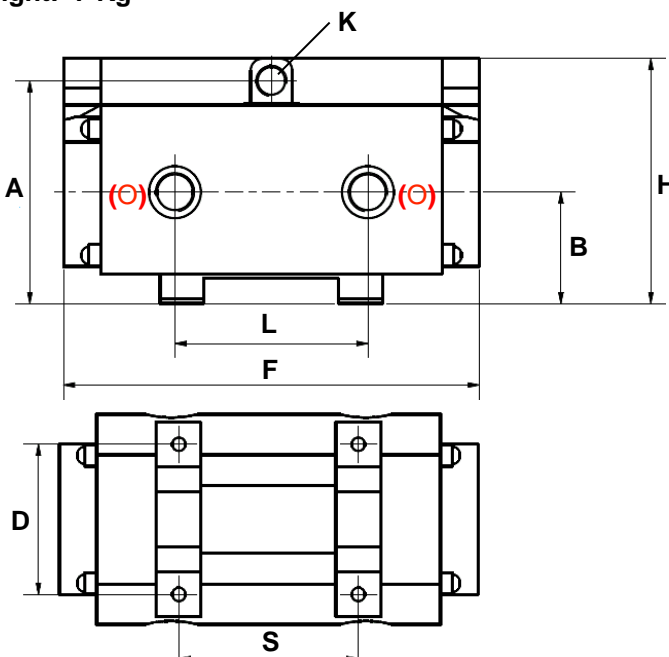

A	130 mm	K (airhose)	Ø12 mm
B	65 mm	L	130 mm
C	75 mm	S	100 mm
D	115 mm	W	120 mm
E	15 mm	F	275mm
H	145 mm	in-outlets	(O) 1/2 "

- double acting - *pd* pumps[®]



Test report included!
Prüfbericht inklusive!



- Capacity max. 2 x 70 l/min
- Separate operating pump chambers
- 3/4" connections
- High suction vacuum (9,5 mtr)
- Double acting (low liquid pulsation!)
- Pressure up to 7 bar
- Viscosity up to 3000 cP
- Max. sizes solid parts in liquid 3 mm
- Low noise (68 dBA) & vibration
- Machined POM-C, PTFE or PVC bodies
- Standard PTFE / NBR backup Diaphragms
- Only few liquid wetted parts
- Suitable for abrasive liquids
- Significant low air-consumption !
- Very compact design
- With ATEX certification
- Operating in each position
- Dry running capability
- Low maintenance costs



Equipped with
PEEK flat-valve technology,
means high stroke frequency

Ausgeführt mit
PEEK Flachventiltechnik
d.h. schnelle Hubfrequenz

- Kapazität max. 2 X 70 l/Min.
- Pumpkammern separat in Betrieb
- 3/4" Anschlüsse
- Hohe Saugleistung (9,5 m)
- Doppeltwirkend (geringes Pulsieren ausreichend)
- Druckluft bis zu 7 bar
- Viskosität bis zu 3000 cP
- Feststoffe bis 3 mm
- Niedriger Geräuschpegel (68 dBA) und Pumpvibrationen
- Pumpengehäuse: POM-C, PTFE oder PVC
- Standard PTFE / NBR Stützmembrane
- Nur wenige medienberührte Teile
- Beständig gegen abrasive Flüssigkeiten
- Luftverbrauch erheblich geringer!
- Kompaktes Design
- Mit ATEX-Zertifizierung
- Funktioniert in jeder Positionslage
- Trockenlauf geeignet
- Niedrige Wartungskosten

PD pumps

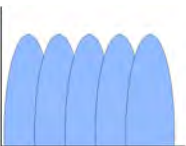

High stroke frequency,
means **low liquid pulsation**
Durch schnelle Hubfrequenz
geringe Pulsation der Flüssigkeit

AODD pumps



low stroke frequency,
means **high liquid pulsation**
langsame Hubfrequenz
hohe Pulsation der Flüssigkeit

APPLICATIONS

CHEMICALS • SOLVENTS • PLATING • ACIDS • OILS • INKS • GLUES • ALKALIES • ENAMEL
POLYESTER PAINT • WASTE WATER • COOLING LIQUIDS • FOAMS • HYDRAULIC OILS

Flowchart / Flussdiagramm

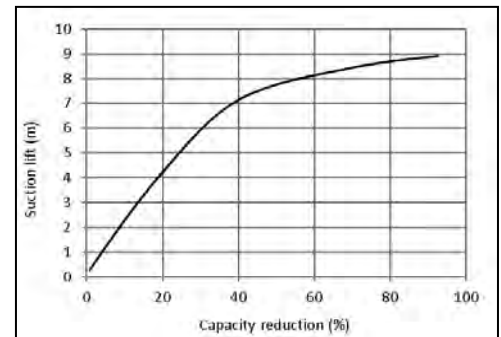
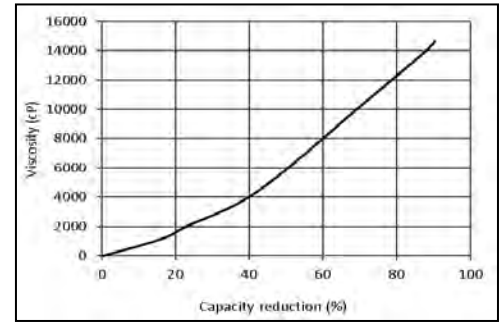
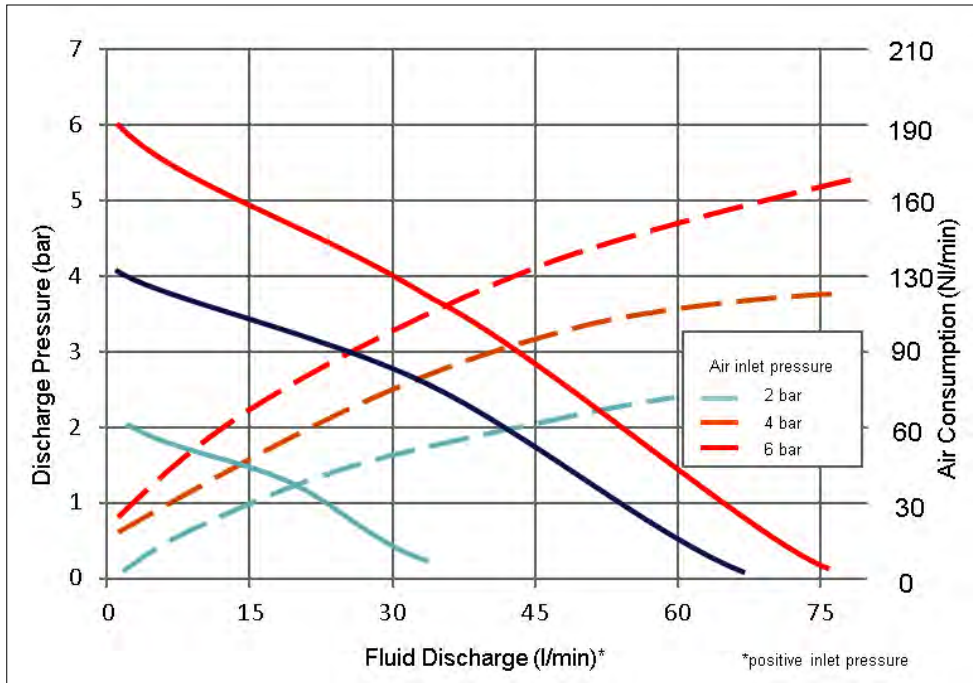

Available types - Verfügbare Typen

Type	liquid wetted parts – Flüssigkeitsberührte Teile
ADF140-POM-TW	POM-C / PTFE / SST (316) / PEEK
ADF140-POM-TW-C	POM-C / PTFE / PEEK / Ceramic
ADF140-PVC-TW	PVC / PTFE / SST (316) / PEEK
ADF140-PVC-TW-C	PVC / PTFE / PEEK / Ceramic
ADF140-PTFE-TW	PTFE / SST (316) / PEEK
ADF140-PTFE-TW-C	PTFE / PEEK / Ceramic

Max. weight: 9 Kg

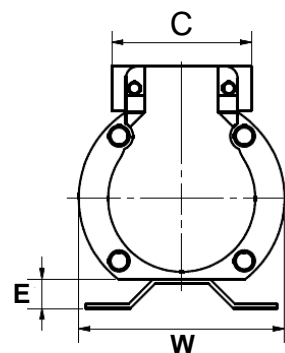
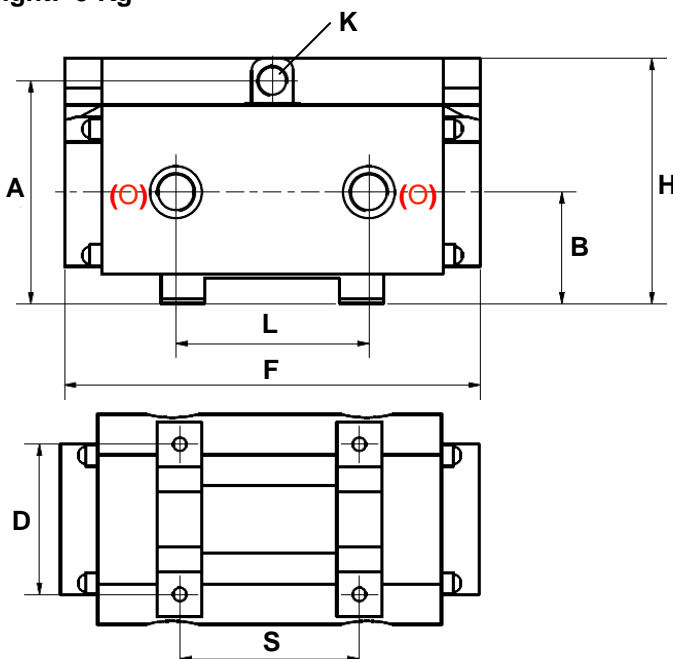

A	130 mm	K (airhose)	Ø12 mm
B	75 mm	L	130 mm
C	75 mm	S	100 mm
D	115 mm	W	140 mm
E	15 mm	F	275 mm
H	165 mm	in-outlets	(O) 3/4 "



Test report included!
Prüfbericht inklusive!



- Capacity 1 – 30 l/min
- 1/2" connections
- High suction lift (9,4 mtr)
- Viscosity up to 3000 cP
- Max. sizes solid parts in liquid 3 mm
- Equipped with PEEK flat-valves
- Low noise (65 dBa) & low vibration
- Full machined Alu. PP. SST pump bodies
- Standard PTFE / NBR backup Diaphragms
- Only few liquid wetted parts
- Epoxy coated alumium parts
- Suitable for abrasive liquids
- Excellent abrasive liquid resistance
- Up to 35% lower air-consumption !
- Very compact design
- With ATEX certification
- Operating in each position
- Dry running capability
- Low maintenance costs



Equipped with
PEEK flat-valve technology,
means high stroke frequency

Ausgeführt mit
PEEK Flachventiltechnik
d.h. schnelle Hubfrequenz

- Kapazität 1 - 30 l/Min.
- 1/2" Anschlüsse
- Hohe Saugleistung (9,4 m)
- Viskosität bis zu 3000 cP
- Feststoffe bis 3 mm
- Ausgeführt mit PEEK-Flachventilen
- Äusserst leise (65 dBa) und geringe Pulsation
- Machinell bearbeitetes Alu. PP. und Edelstahlgehäuse
- Standard PTFE / NBR Stützmembrane
- Nur wenig medienberührte Teile
- Standardbeschichtung Epoxy
- Beständig gegen abrasive Flüssigkeiten
- Bis zu 35% weniger Luftverbrauch
- Kompaktes Design
- Mit ATEX-Zertifizierung
- Funktioniert in jeder Positionslage
- Trockenlauf geeignet
- Niedrige Wartungskosten

PD pumps

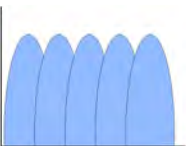

High stroke frequency,
means **low liquid pulsation**
Durch schnelle Hubfrequenz
geringe Pulsation der Flüssigkeit

AODD pumps



low stroke frequency,
means **high liquid pulsation**
langsame Hubfrequenz
hohe Pulsation der Flüssigkeit

APPLICATIONS

CHEMICALS • SOLVENTS • PLATING • ACIDS • OILS • INKS • GLUES • ALKALIES • ENAMEL
POLYESTER PAINT • WASTE WATER • COOLING LIQUIDS • FOAMS • HYDRAULIC OILS

Flowchart 1/2" Series / Flussdiagramm 1/2" Serien

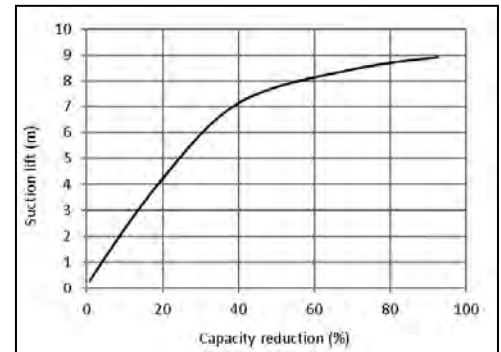
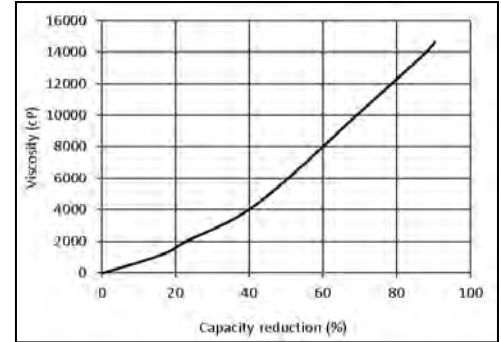
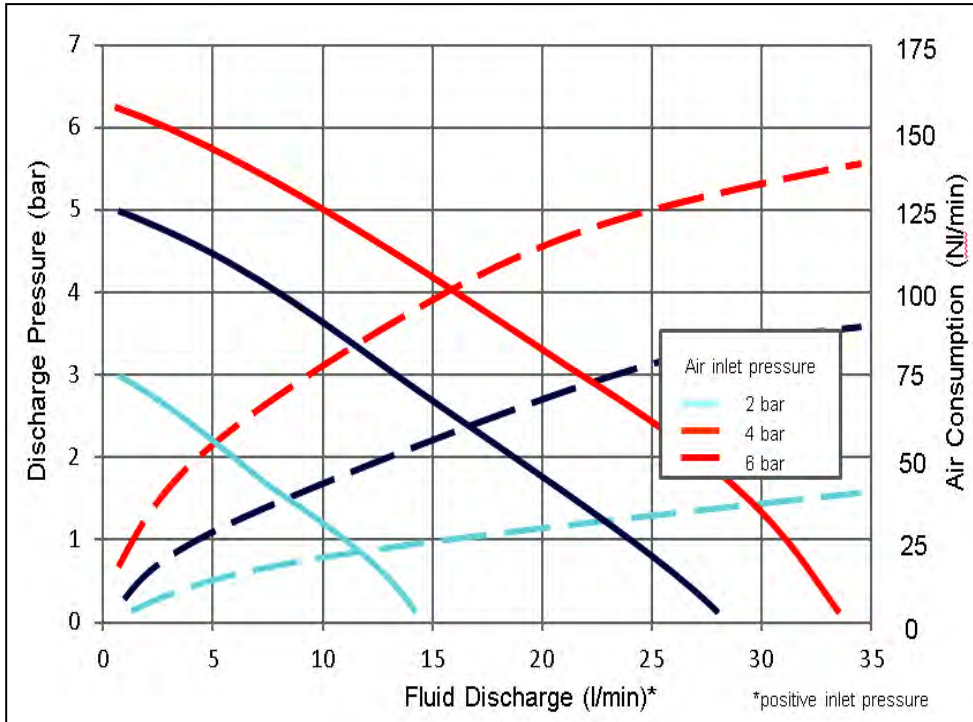

Available types - Verfügbare Typen

Type	liquid wetted parts – Flüssigkeitsberührte Teile
ADF-30-AXT	Alu. / PTFE / SST (316) / PEEK
ADF-30-AXT-C	Alu. / PTFE / PEEK / Ceramic
ADF-30-PXT	PP / PTFE / SST (316) / PEEK
ADF-30-PXT-C	PP / PTFE / PEEK / Ceramic
ADF-30-SST	SST (316) / PTFE / PEEK
ADF-30-SST-C	SST (316) / PTFE / PEEK / Ceramic

Pump body

- A = Aluminium
- P = Machined Polypropylene
- X = ATEX Certified
- T = PTFE Diaphragms
- C = Ceramic shaft

Max. weight: 8 Kg

A	65 mm	K	12 mm
B	65 mm	L	145 mm
C	100 mm	R	15 mm
D	100 mm	S	120 mm
E	15 mm	W	140 mm
H	145 mm	in-outlet	1/2"

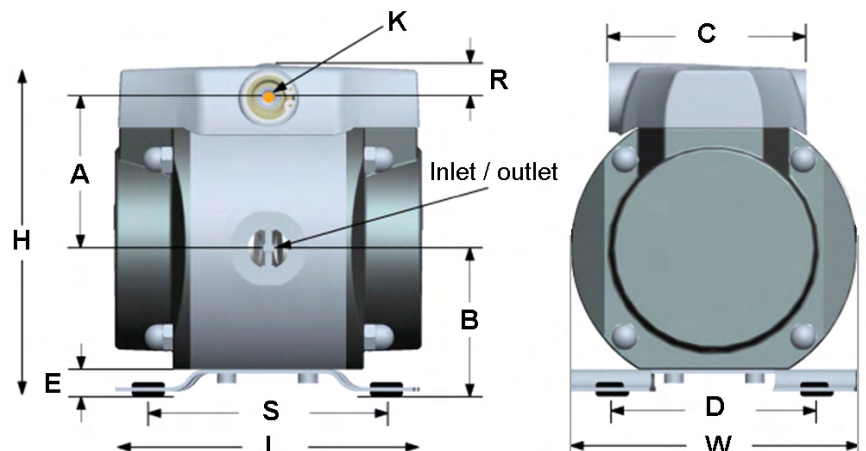



Test report included!
Prüfbericht inklusive!



- Capacity 1 – 60 l/min
- 3/4" connections
- High suction lift (9,4 mtr)
- Viscosity up to 3000 cP
- Max. sizes solid parts in liquid 4 mm
- Equipped with PEEK flat-valves
- Low noise (65 dBA) & low vibration
- Full machined Alu. PP. SST pump bodies
- Standard PTFE / NBR backup Diaphragms
- Only few liquid wetted parts
- Epoxy coated Aluminium parts
- Suitable for abrasive liquids
- Up to 35% lower air-consumption !
- Very compact design
- With ATEX certification
- Operating in each position
- Dry running capability
- Low maintenance costs

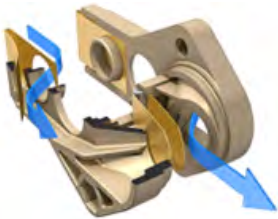

Equipped with
PEEK flat-valve technology,
means high stroke frequency

Ausgeführt mit
PEEK Flachventiltechnik
d.h. schnelle Hubfrequenz

- Kapazität 1 - 60 l/Min.
- 3/4" Anschlüsse
- Hohe Saugleistung (9,4 m)
- Viskosität bis zu 3000 cP
- Feststoffe bis 4 mm
- Ausgeführt mit PEEK-Flachventilen
- Äusserst leise (65 dBA) und geringe Pulsation
- Machinell bearbeitetes Alu. PP. und Edelstahlgehäuse
- Standard PTFE / NBR Stützmembrane
- Nur wenig medienberührte Teile
- Standardbeschichtung Epoxy
- Beständig gegen abrasive Flüssigkeiten
- Bis zu 35% weniger Luftverbrauch
- Kompaktes Design
- Mit ATEX-Zertifizierung
- Funktioniert in jeder Positionslage
- Trockenlauf geeignet
- Niedrige Wartungskosten

PD pumps

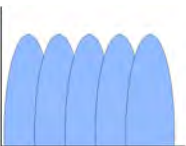

High stroke frequency,
means **low liquid pulsation**
Durch schnelle Hubfrequenz
geringe Pulsation der Flüssigkeit

AODD pumps



low stroke frequency,
means **high liquid pulsation**
langsame Hubfrequenz
hohe Pulsation der Flüssigkeit

APPLICATIONS

CHEMICALS • SOLVENTS • PLATING • ACIDS • OILS • INKS • GLUES • ALKALIES • ENAMEL
POLYESTER PAINT • WASTE WATER • COOLING LIQUIDS • FOAMS • HYDRAULIC OILS

Flowchart 3/4" Series / Flussdiagramm 3/4" Serien

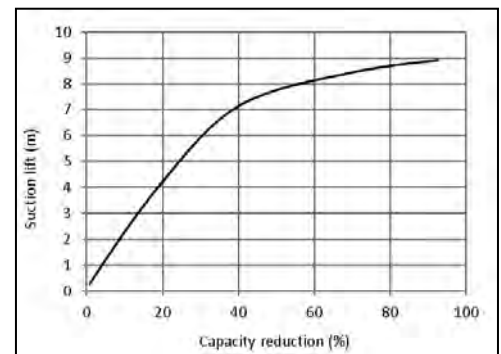
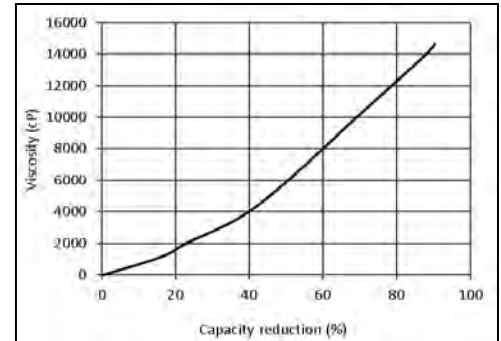
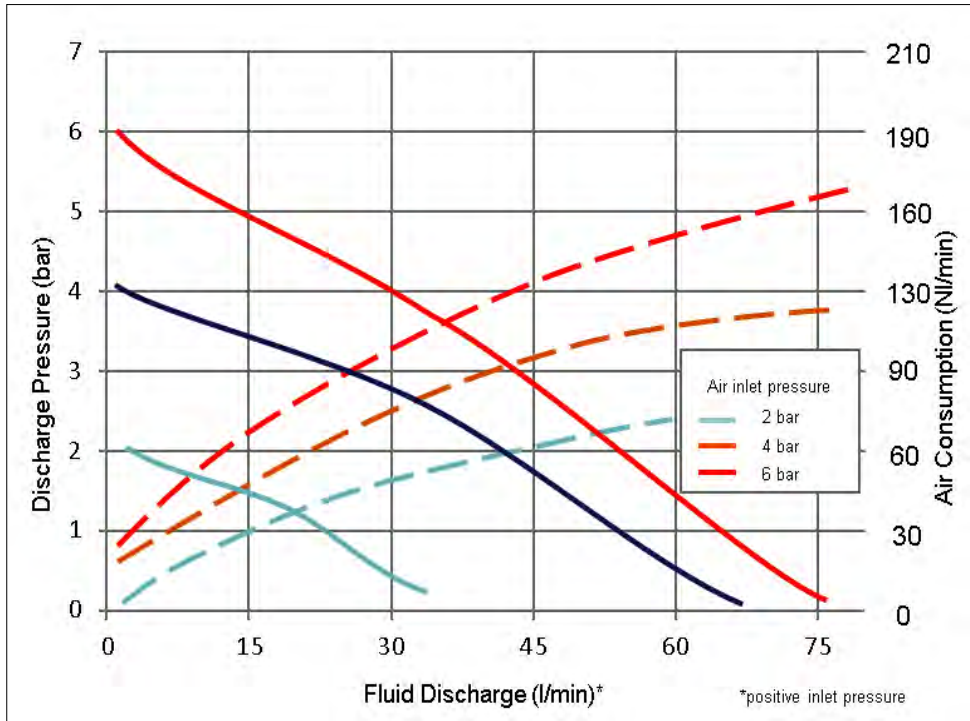

Available types - Verfügbare Typen

Type	liquid wetted parts – Flüssigkeitsberührte Teile
ADF-60-AXT	Alu. / PTFE / SST (316) / PEEK
ADF-60-AXT-C	Alu. / PTFE / PEEK / Ceramic
ADF-60-PXT	PP / PTFE / SST (316) / PEEK
ADF-60-PXT-C	PP / PTFE / PEEK / Ceramic
ADF-60-SST	SST (316) / PTFE / PEEK
ADF-60-SST-C	SST (316) / PTFE / PEEK / Ceramic

Pump body

- A = Aluminium
- P = Machined Polypropylene
- X = ATEX Certified
- T = PTFE Diaphragms
- C = Ceramic shaft

Max. weight: 10 Kg

A	75 mm	K	12 mm
B	75 mm	L	145 mm
C	100 mm	R	15 mm
D	100 mm	S	120 mm
E	15 mm	W	140 mm
H	165 mm	in-outlet	3/4"

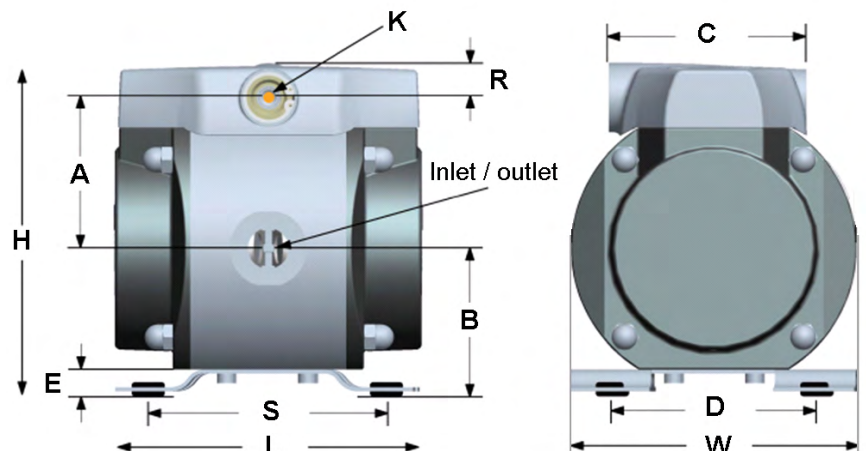



Test report included!
Prüfbericht inklusive!



- Capacity 5 – 120 l/min
- 1¼" connections
- High suction vacuum (9,5 mtr)
- Viscosity up to 3000 cP
- Max. sizes solid parts in liquid 5 mm
- Equipped with PEEK flat-valves
- Low noise (68 dBA) & vibration
- Full machined Alu. PP. SST pump bodies
- Standard PTFE / NBR backup Diaphragms
- Only few liquid wetted parts
- Epoxy coated Aluminium parts
- Suitable for abrasive liquids
- Up to 35% lower air-consumption !
- Very compact design
- With ATEX certification
- Operating in each position
- Dry running capability
- Low maintenance costs

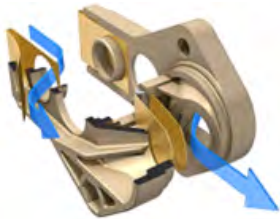

Equipped with
PEEK flat-valve technology,
means high stroke frequency

Ausgeführt mit
PEEK Flachventiltechnik
d.h. schnelle Hubfrequenz

- Kapazität 5 - 120 l/Min.
- 1¼" Anschlüsse
- Hohe Saugleistung (9,5 m)
- Viskosität bis zu 3000 cP
- Feststoffe bis 5 mm
- Ausgeführt mit PEEK-Flachventilen
- Äusserst leise (68 dBA) und geringe Pulsation
- Machinell bearbeitetes Alu. PP. und Edelstahlgehäuse
- Standard PTFE / NBR Stützmembrane
- Nur wenige medienberührte Teile
- Standardbeschichtung Epoxy
- Beständig gegen abrasive Flüssigkeiten
- Bis zu 35% weniger Luftverbrauch
- Kompaktes Design
- Mit ATEX-Zertifizierung
- Funktioniert in jeder Positionslage
- Trockenlauf geeignet
- Niedrige Wartungskosten

PD pumps

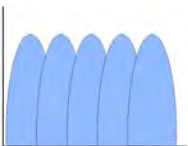

High stroke frequency,
means **low liquid pulsation**
Durch schnelle Hubfrequenz
geringe Pulsation der Flüssigkeit

AODD pumps



low stroke frequency,
means **high liquid pulsation**
langsame Hubfrequenz
hohe Pulsation der Flüssigkeit

APPLICATIONS

CHEMICALS • SOLVENTS • PLATING • ACIDS • OILS • INKS • GLUES • ALKALIES • ENAMEL
POLYESTER PAINT • WASTE WATER • COOLING LIQUIDS • FOAMS • HYDRAULIC OILS

Flowchart 1 1/4" Series / Flussdiagramm 1 1/4" Serien

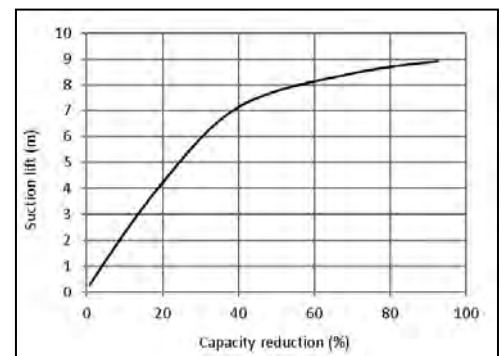
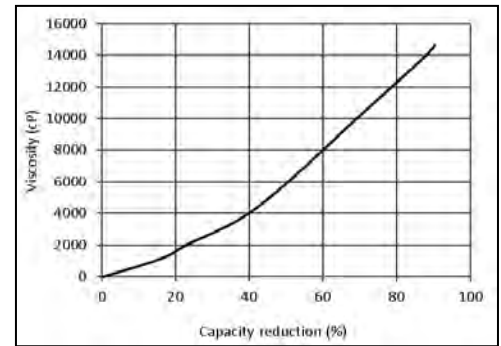
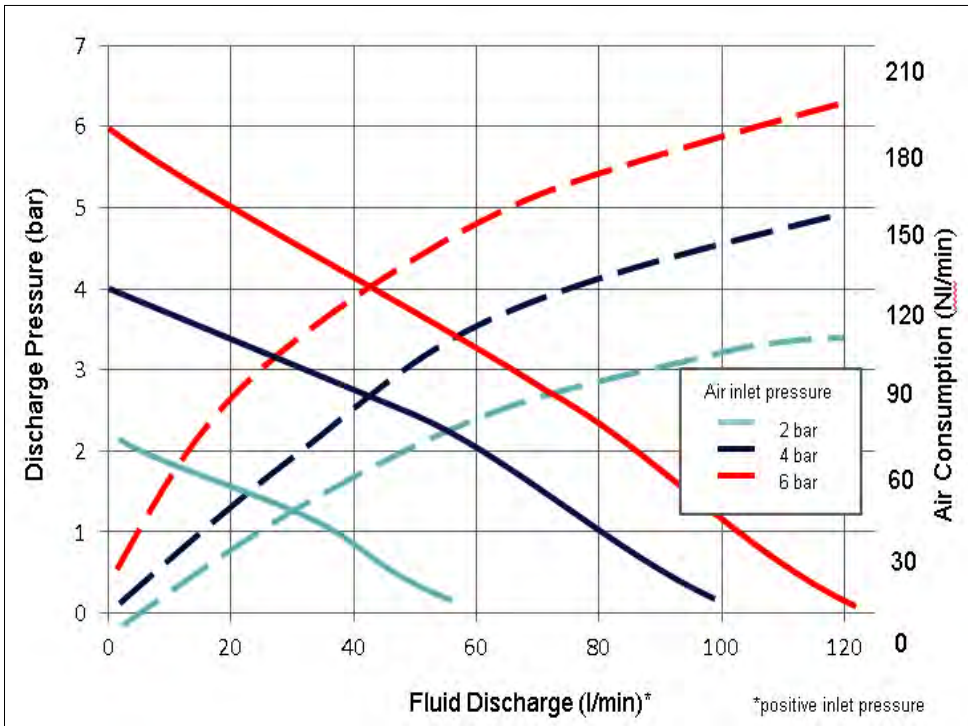

Available types - Verfügbare Typen

Type	liquid wetted parts – Flüssigkeitsberührte Teile
ADF-120-AXT	Alu. / PTFE / SST (316) / PEEK
ADF-120-AXT-C	Alu. / PTFE / PEEK / Ceramic
ADF-120-PXT	PP / PTFE / SST (316) / PEEK
ADF-120-PXT-C	PP / PTFE / PEEK / Ceramic
ADF-120-SST	SST (316) / PTFE / PEEK
ADF-120-SST-C	SST (316) / PTFE / PEEK / Ceramic

Pump body

A = Aluminium
 P = Machined Polypropylene

X = ATEX Certified
 T = PTFE Diaphragms
 C = Ceramic shaft

Max. weight: 18 Kg

A	100 mm	K	12 mm
B	100 mm	L	180 mm
C	100 mm	R	15 mm
D	135 mm	S	150 mm
E	15 mm	W	185 mm
H	210 mm	in-outlet	1-1/4"

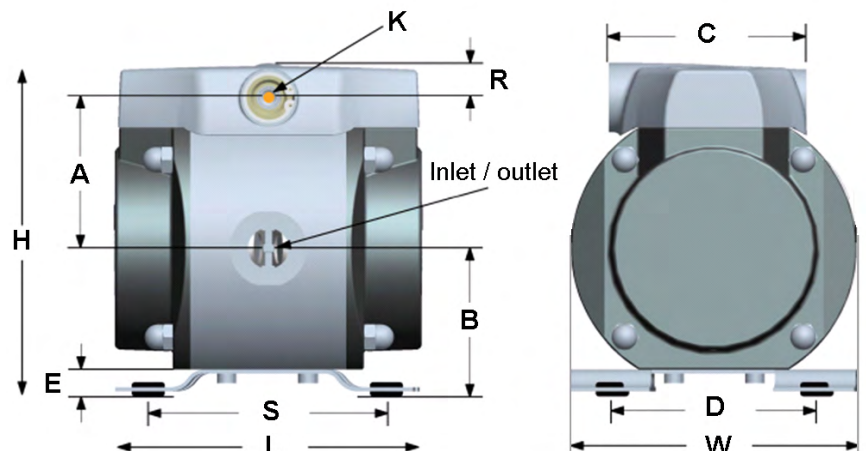



Test report included!
Prüfbericht inklusive!



- Capacity 1 - 60 l/min
- 1/2" connection in several positions
- High suction lift (8 mtr.)
- Standard PTFE / NBR backup Diaphragms
- Ceramic air-valve system (lubefree)
- Suitable for viscosity liquids >3000 cP
- Max. sizes solid parts in liquid 2,5 mm
- Low noise (72 dBa)
- Pump body: POM-C, PTFE or PVC
- Suitable for abrasive liquids
- Low air-consumption !
- Dry running capability
- Low maintenance and parts costs
- Bolted (SST) leakage free design
- No Air leakage at liquid stop
- Flat-valve technology (on request)



Maintenance Free
Ceramic Air-Valve Parts

Wartungsfrei
Lüftungsventilteile aus Keramik

- Kapazität 1 - 60 l/Min.
- Variable 1/2" Anschlüsse
- Hohe Saugleistung (8 m)
- Standard PTFE / NBR Stützmembrane
- Keramik-Luft-Ventilsystem (fettfrei)
- Geeignet für viskose Medien >3000 cP
- Feststoffe bis 2,5 mm
- Äusserst leise (72 dBa)
- Pumpengehäuse: POM-C, PTFE oder PVC
- Beständig gegen abrasive Flüssigkeiten
- Geringer Luftverbrauch
- Trockenlauf geeignet
- Niedrige Wartungs- und Ersatzteilkosten
- Bolzen (SST) leckagefreie Ausführung
- Bei Betriebsstopp kein Druckluftverlust
- Flachventiltechnik (auf Anfrage)

APPLICATIONS

CHEMICALS • SOLVENTS • PLATING • ACIDS • OILS • INKS • GLUES • ALKALIES • ENAMEL
POLYESTER PAINT • WASTE WATER • COOLING LIQUIDS • FOAMS • HYDRAULIC OILS

Flowchart / Flussdiagramm

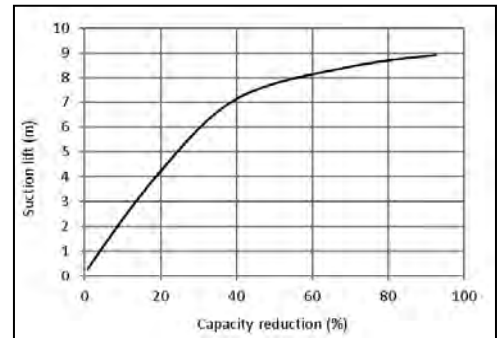
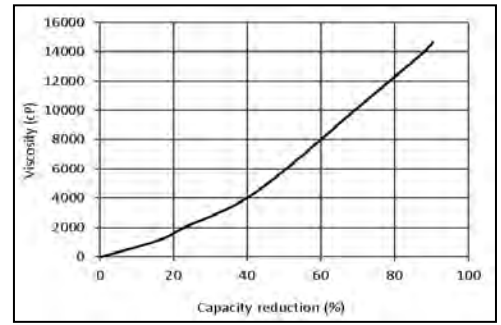
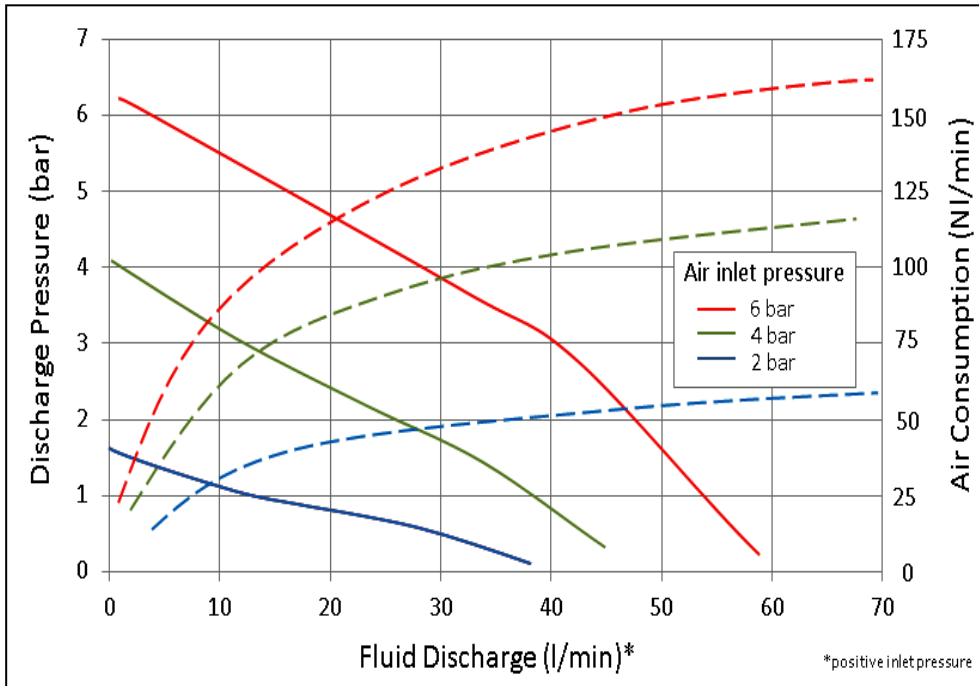

Available types - Verfügbare Typen

ATEX Version on request
ATEX Version auf Anfrage

Type	liquid wetted parts – Flüssigkeitsberührte Teile
TAD60-POM-TW	POM-C / PTFE
TAD60-POM-X	POM-C / Santoprene
TAD60-PVC-TW	PVC / PTFE
TAD60-PVC-X	PVC / Santoprene
TAD60-PTFE-TW	PTFE / PTFE)
TAD60-PTFE-X	PTFE / Santoprene

Max. weight: 8 Kg

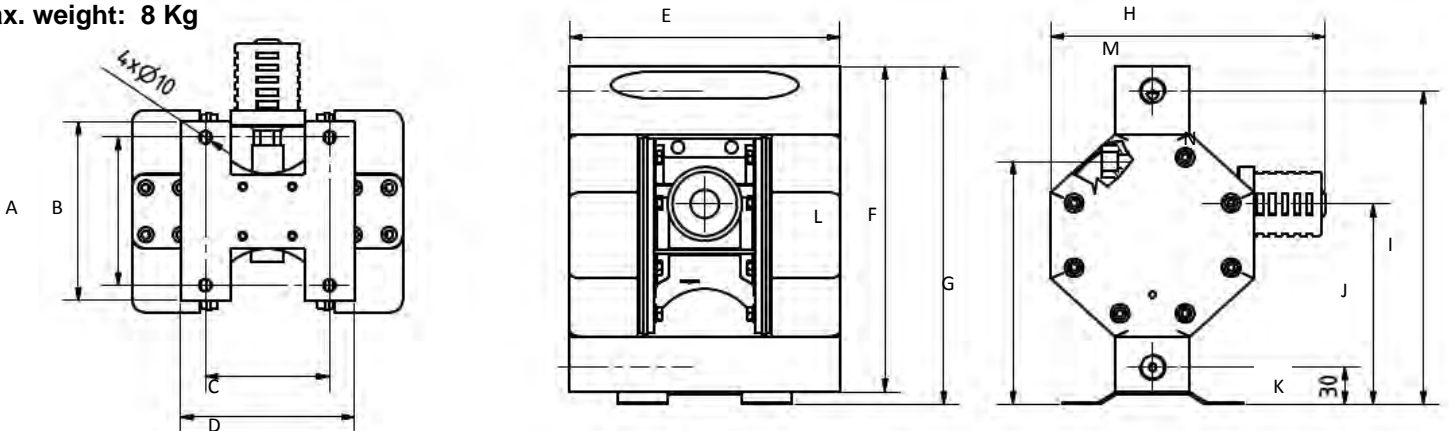

A	145 mm	G	197 mm	N (Air in/out)	3/8" female
B	120 mm	H	221 mm		
C	100 mm	J	163 mm		
D	140 mm	K	30 mm		
E	218 mm	L	264 mm		
F	274 mm	M (Liquid in/out)	1/2" female mm		



Test report included!
Prüfbericht inklusive!



- Capacity 5 - 120 l/min
- 3/4" connections
- High suction lift (8,5 mtr)
- Standard PTFE / NBR backup Diaphragms
- Ceramic air-valve system (lubefree)
- Suitable for viscosity liquids >3000 cP
- Max. sizes solid parts in liquid 4 mm
- Low noise (77 dBa)
- Pump body: POM-C, PTFE or PVC
- Suitable for abrasive liquids
- Low air-consumption !
- Dry running capability
- Low maintenance and parts costs
- Bolted (SST) leakage free design
- No Air leakage at liquid stop
- Flat-valve technology (on request)



Maintenance Free
Ceramic Air-Valve Parts

Wartungsfrei
Lüftungsventilteile aus Keramik

- Kapazität 5 - 120 l/Min.
- Variable 3/4" Anschlüsse
- Hohe Saugleistung (8,5 m)
- Standard PTFE / NBR Stützmembrane
- Keramik-Luft-Ventilsystem (fettfrei)
- Geeignet für viskose Medien >3000 cP
- Feststoffe bis 4 mm
- Äusserst leise (77 dBa)
- Pumpengehäuse: POM-C, PTFE oder PVC
- Beständig gegen abrasive Flüssigkeiten
- Geringer Luftverbrauch
- Trockenlauf geeignet
- Niedrige Wartungs- und Ersatzteilkosten
- Bolzen (SST) leckagefreie Ausführung
- Bei Betriebsstopp kein Druckluftverlust
- Flachventiltechnik (auf Anfrage)

APPLICATIONS

CHEMICALS • SOLVENTS • PLATING • ACIDS • OILS • INKS • GLUES • ALKALIES • ENAMEL
POLYESTER PAINT • WASTE WATER • COOLING LIQUIDS • FOAMS • HYDRAULIC OILS

Flowchart / Flussdiagramm

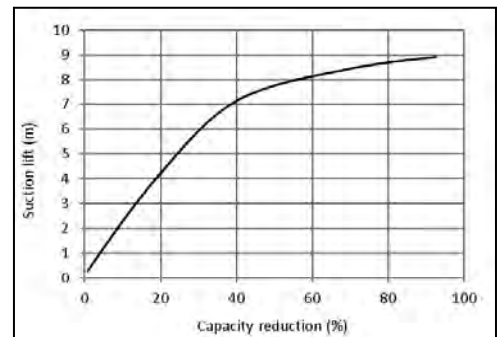
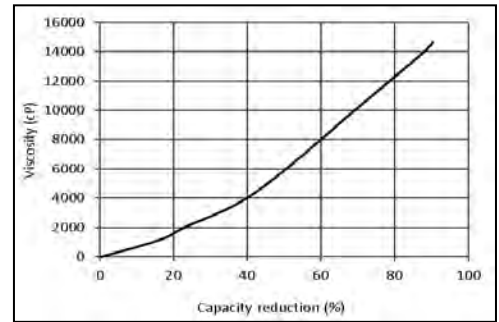
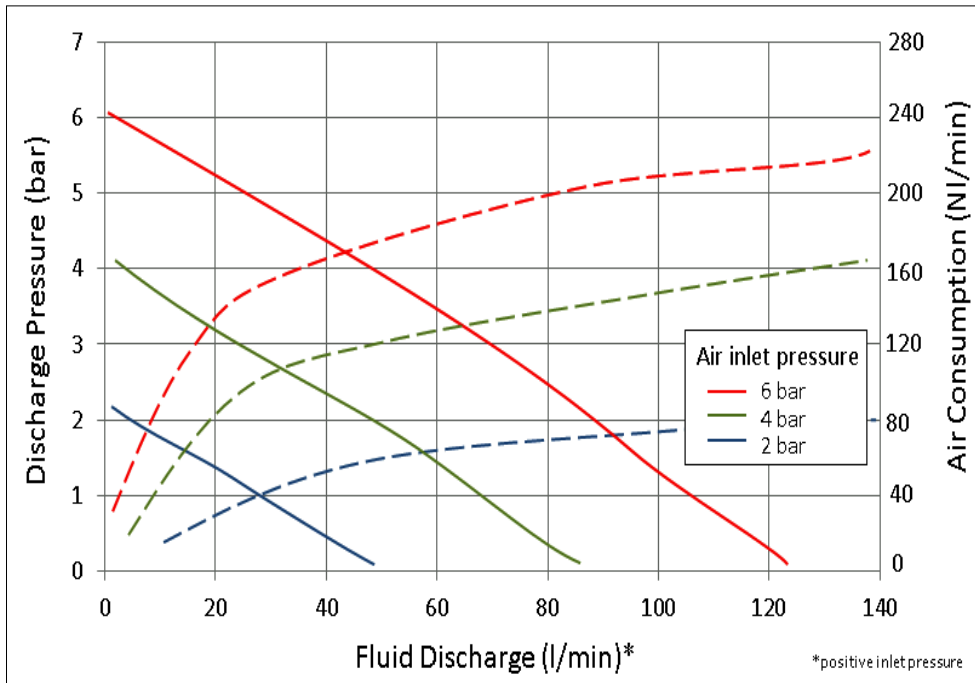

Available types - Verfügbare Typen

ATEX Version on request
ATEX Version auf Anfrage

Type	liquid wetted parts – Flüssigkeitsberührte Teile
TAD120-POM-TW	POM-C / PTFE
TAD120-POM-X	POM-C / Santoprene
TAD120-PVC-TW	PVC / PTFE
TAD120-PVC-X	PVC / Santoprene
TAD120-PTFE-TW	PTFE / PTFE
TAD120-PTFE-X	PTFE / Santoprene

Max. weight: 14 Kg

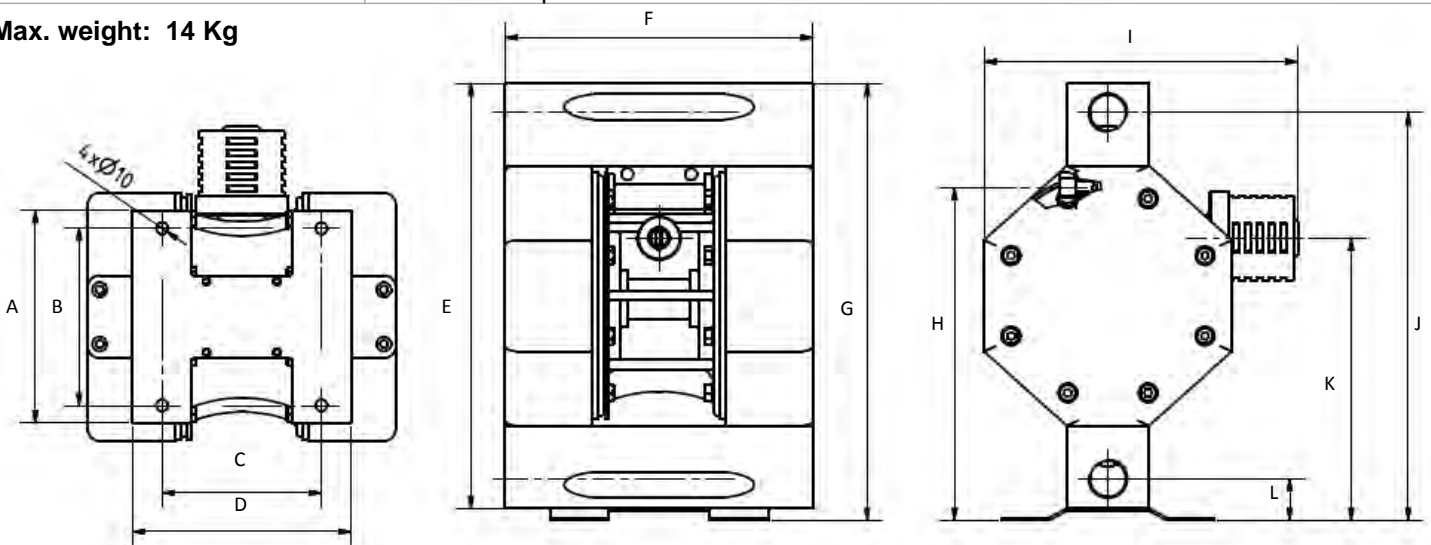

A	180 mm	E	360 mm	I	266 mm
B	150 mm	F	261 mm	J	345 mm -3/4"
C	135 mm	G	370 mm	K	239 mm
D	185 mm	H	282 mm	L	30 mm 3/4"



Test report included!
Prüfbericht inklusive!



Maintenance Free
Ceramic Air-Valve Parts

Wartungsfrei
Lüftungsventilteile aus Keramik

- Capacity 5 - 150 l/min
- 1" connections
- High suction lift (8,5 mtr)
- Standard PTFE / NBR backup Diaphragms
- Ceramic air-valve system (lubefree)
- Suitable for viscosity liquids >3000 cP
- Max. sizes solid parts in liquid 5 mm
- Low noise (77 dBa)
- Pump body: POM-C, PTFE or PVC
- Suitable for abrasive liquids
- Low air-consumption !
- Dry running capability
- Low maintenance and parts costs
- Bolted (SST) leakage free design
- No Air leakage at liquid stop
- Flat-valve technology (on request)

- Kapazität 5 - 150 l/Min.
- 1" Anschlüsse
- Hohe Saugleistung (8,5 m)
- Standard PTFE / NBR Stützmembrane
- Keramik-Luft-Ventilsystem (fettfrei)
- Geeignet für viskose Medien >3000 cP
- Feststoffe bis 5 mm
- Äusserst leise (77 dBa)
- Pumpengehäuse: POM-C, PTFE oder PVC
- Beständig gegen abrasive Flüssigkeiten
- Geringer Luftverbrauch
- Trockenlauf geeignet
- Niedrige Wartungs- und Ersatzteilkosten
- Bolzen (SST) leckagefreie Ausführung
- Bei Betriebsstopp kein Druckluftverlust
- Flachventiltechnik (auf Anfrage)

APPLICATIONS

CHEMICALS • SOLVENTS • PLATING • ACIDS • OILS • INKS • GLUES • ALKALIES • ENAMEL
POLYESTER PAINT • WASTE WATER • COOLING LIQUIDS • FOAMS • HYDRAULIC OILS

Flowchart / Flussdiagramm

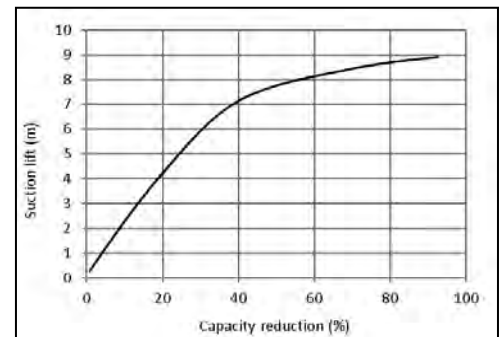
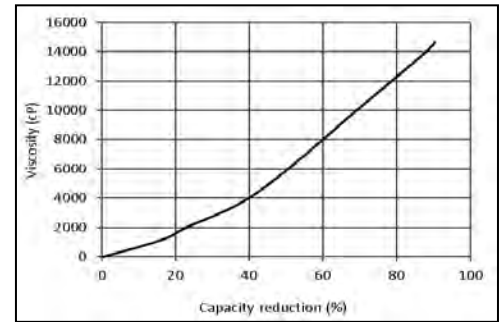
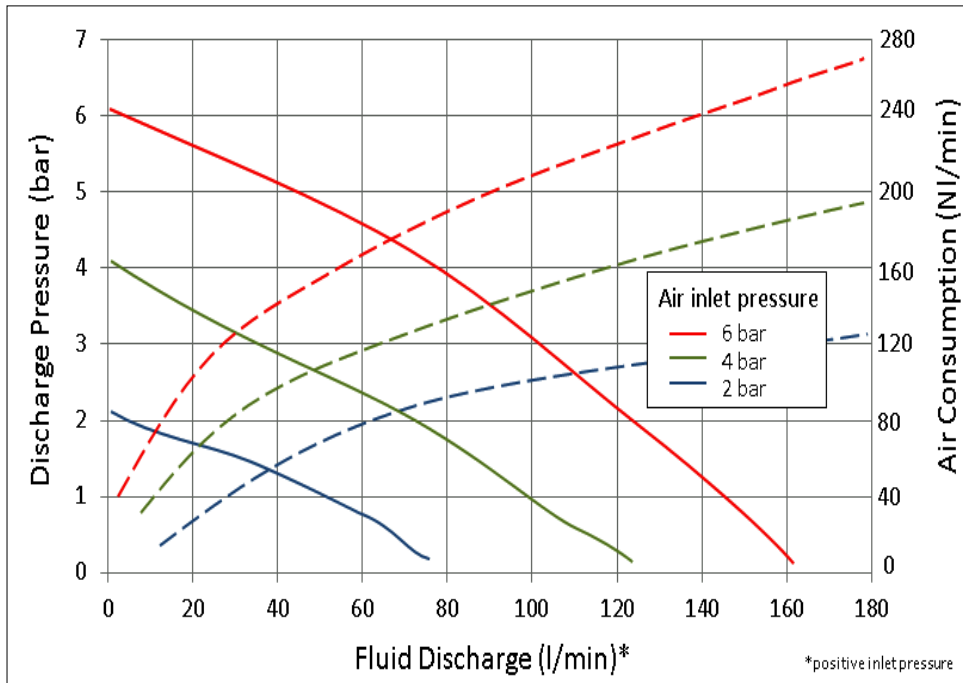

Available types - Verfügbare Typen

ATEX Version on request
ATEX Version auf Anfrage

Type	liquid wetted parts – Flüssigkeitsberührte Teile
TAD150-POM-TW	POM-C / PTFE
TAD150-POM-X	POM-C / Santoprene
TAD150-PVC-TW	PVC / PTFE
TAD150-PVC-X	PVC / Santoprene
TAD150-PTFE-TW	PTFE / PTFE
TAD150-PTFE-X	PTFE / Santoprene

Max. weight: 14 Kg

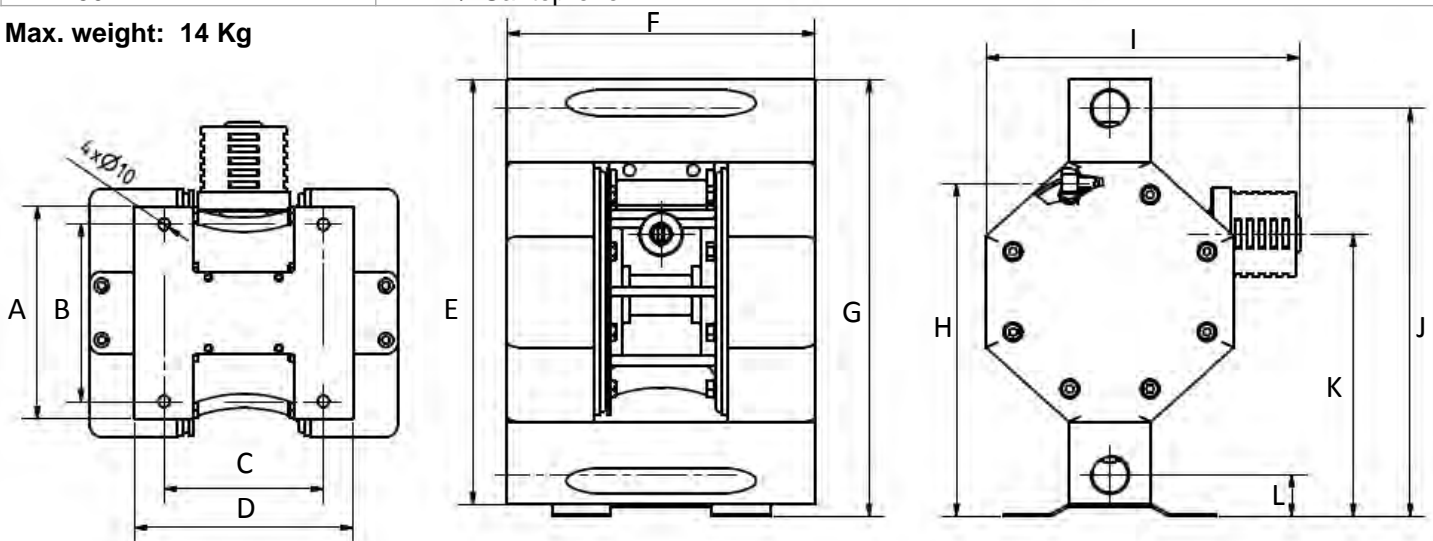

A	180 mm	E	360 mm	I	266 mm
B	150 mm	F	261 mm	J	345 mm 1"
C	135 mm	G	370 mm	K	239 mm
D	185 mm	H	282 mm	L	30 mm 1"



Test report included!
Prüfbericht inklusive!



Maintenance Free
Ceramic Air-Valve Parts

Wartungsfrei
Lüftungsventilteile aus Keramik

- Capacity 5 - 260 l/min
- 1-1/2" connections
- High suction lift (8,5 mtr)
- Standard PTFE / NBR backup Diaphragms
- Ceramic air-valve system (lubefree)
- Suitable for viscosity liquids >3000 cP
- Max. sizes solid parts in liquid 6 mm
- Low noise (77 dBA)
- Pump body: POM-C, PTFE or PVC
- Suitable for abrasive liquids
- Low air-consumption !
- Dry running capability
- Low maintenance and parts costs
- Bolted (SST) leakage free design
- No Air leakage at liquid stop

- Kapazität 5 - 260l/Min.
- 1-1/2" Anschlüsse
- Hohe Saugleistung (8,5 m)
- Standard PTFE / NBR Stützmembrane
- Keramik-Luft-Ventilsystem (fettfrei)
- Geeignet für viskose Medien >3000 cP
- Feststoffe bis 6 mm
- Äusserst leise (77 dBA)
- Pumpengehäuse: POM-C, PTFE oder PVC
- Beständig gegen abrasive Flüssigkeiten
- Geringer Luftverbrauch
- Trockenlauf geeignet
- Niedrige Wartungs- und Ersatzteilkosten
- Bolzen (SST) leckagefreie Ausführung
- Bei Betriebsstopp kein Druckluftverlust

APPLICATIONS

CHEMICALS • SOLVENTS • PLATING • ACIDS • OILS • INKS • GLUES • ALKALIES • ENAMEL
POLYESTER PAINT • WASTE WATER • COOLING LIQUIDS • FOAMS • HYDRAULIC OILS

Flowchart / Flussdiagramm

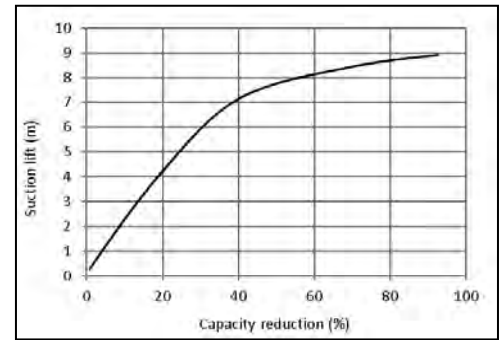
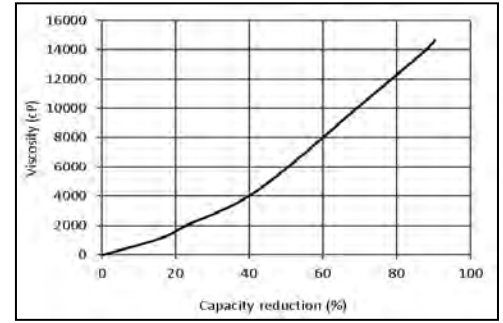
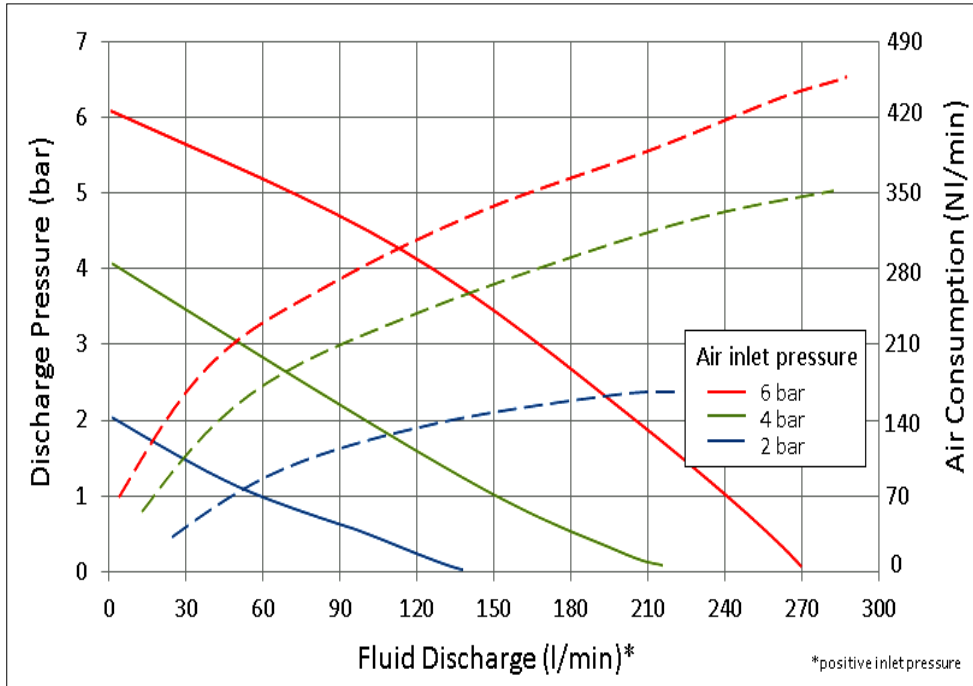

Available types - Verfügbare Typen

ATEX Version on request
ATEX Version auf Anfrage

Type	liquid wetted parts – Flüssigkeitsberührte Teile
TAD260-POM-TW	POM-C / PTFE
TAD260-POM-X	POM-C / Santoprene
TAD260-PVC-TW	PVC / PTFE
TAD260-PVC-X	PVC / Santoprene
TAD260-PTFE-TW	PTFE / PTFE
TAD260-PTFE-X	PTFE / Santoprene

Max. weight: 24 Kg

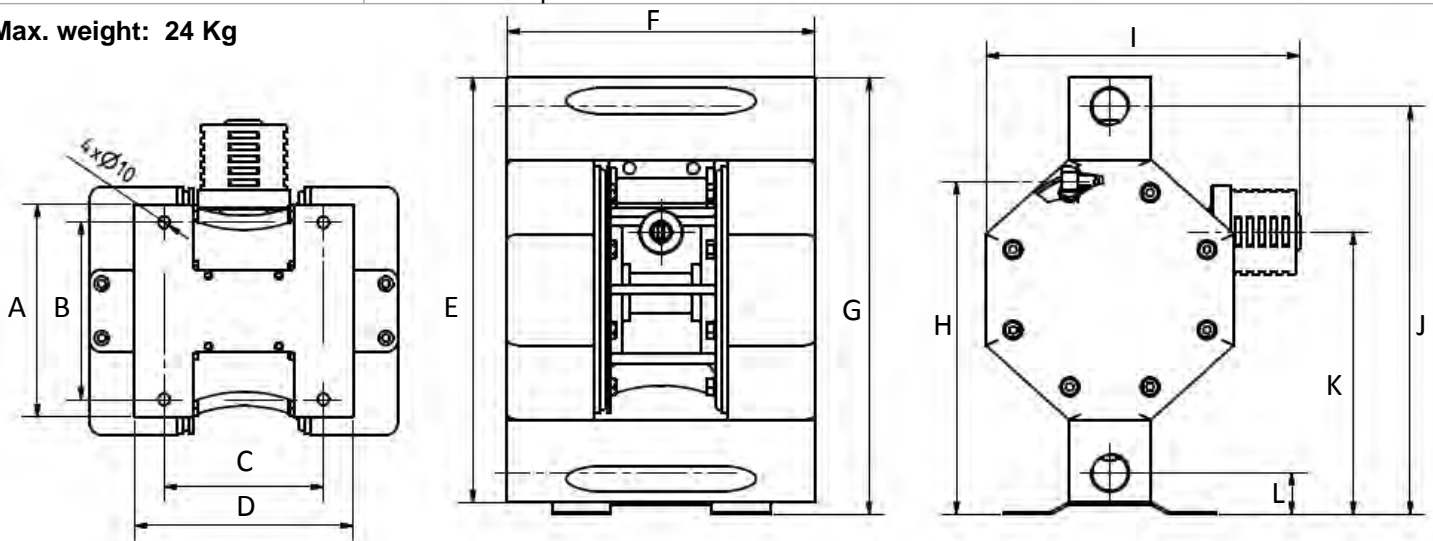

A	180 mm	E	360 mm	I	266 mm
B	150 mm	F	261 mm	J	345 mm 1"
C	135 mm	G	370 mm	K	239 mm
D	185 mm	H	282 mm	L	30 mm 1"



Test report included!
Prüfbericht inklusive!



- Capacity 5 - 550 l/min
- 2" connections
- High suction lift (8,5 mtr)
- Standard PTFE / NBR backup Diaphragms
- Ceramic air-valve system (lubefree)
- Suitable for viscosity liquids >3000 cP
- Max. sizes solid parts in liquid 7 mm
- Low noise (77 dBA)
- Pump body: POM-C, PTFE or PVC
- Suitable for abrasive liquids
- Low air-consumption !
- Dry running capability
- Low maintenance and parts costs
- Bolted (SST) leakage free design
- No Air leakage at liquid stop

- Kapazität 5 - 550 l/Min.
- 2" Anschlüsse
- Hohe Saugleistung (8,5 m)
- Standard PTFE / NBR Stützmembrane
- Keramik-Luft-Ventilsystem (fettfrei)
- Geeignet für viskose Medien >3000 cP
- Feststoffe bis 7 mm
- Äusserst leise (77 dBA)
- Pumpengehäuse: POM-C, PTFE oder PVC
- Beständig gegen abrasive Flüssigkeiten
- Geringer Luftverbrauch
- Trockenlauf geeignet
- Niedrige Wartungs- und Ersatzteilkosten
- Bolzen (SST) leckagefreie Ausführung
- Bei Betriebsstopp kein Druckluftverlust

APPLICATIONS

CHEMICALS • SOLVENTS • PLATING • ACIDS • OILS • INKS • GLUES • ALKALIES • ENAMEL
POLYESTER PAINT • WASTE WATER • COOLING LIQUIDS • FOAMS • HYDRAULIC OILS

Flowchart / Flussdiagramm

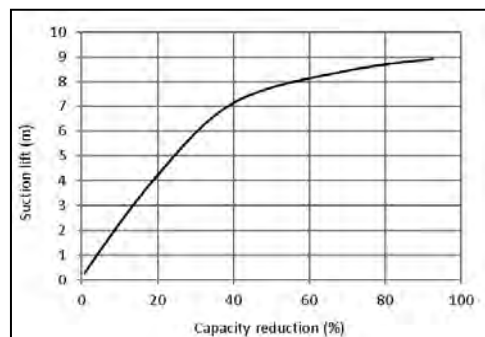
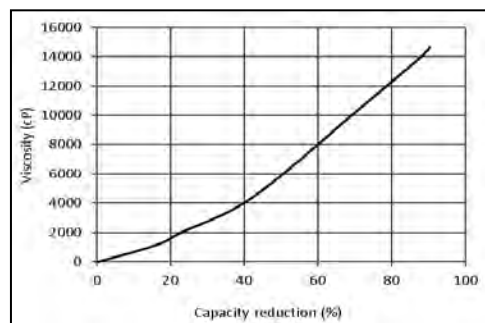
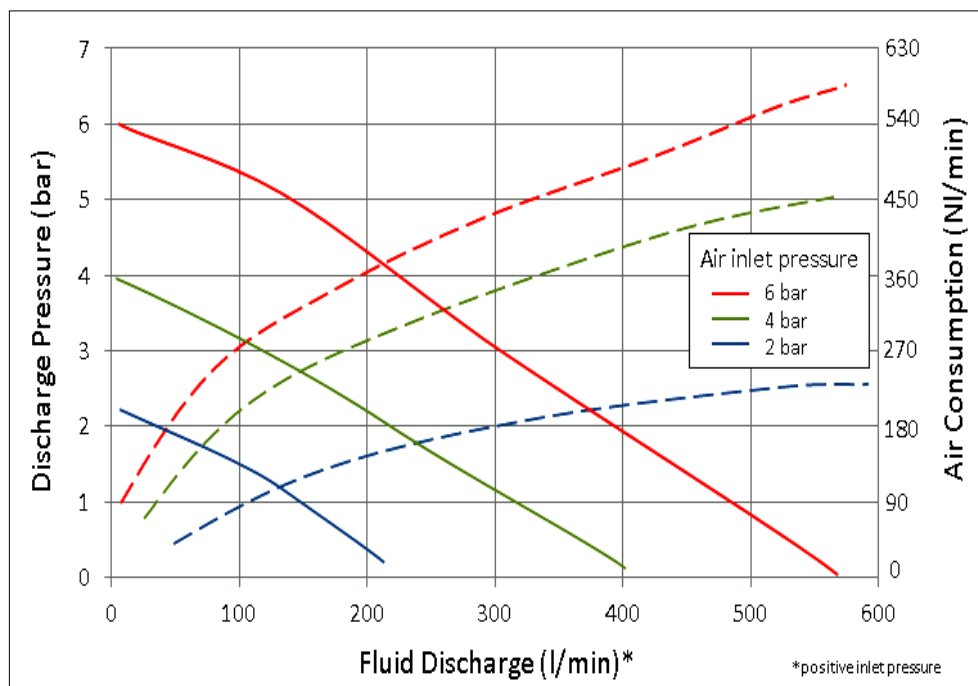

Available types - Verfügbare Typen

ATEX Version on request
ATEX Version auf Anfrage

Type	liquid wetted parts – Flüssigkeitsberührte Teile
TAD550-POM-TW	POM-C / PTFE
TAD550-POM-X	POM-C / Santoprene
TAD550-PVC-TW	PVC / PTFE
TAD550-PVC-X	PVC / Santoprene
TAD550-PTFE-TW	PTFE / PTFE
TAD550-PTFE-X	PTFE / Santoprene

Max. weight: 80 Kg

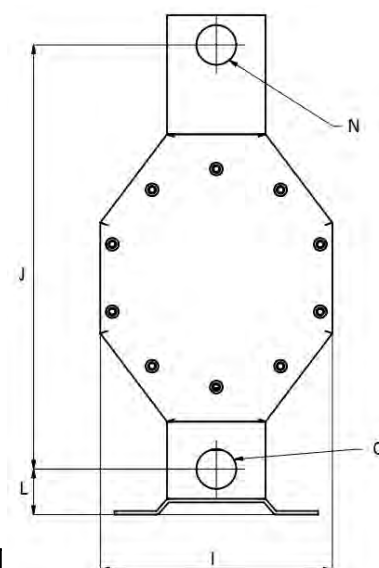
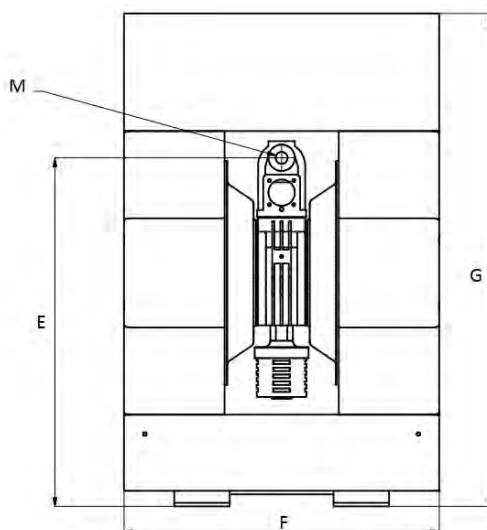
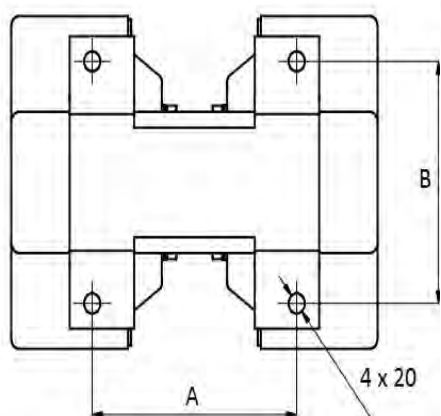

A	254 mm	G	713 mm	M	G1/2
B	240 mm	I	330 mm	N	G2
E	504 mm	J	605 mm	O	G2
F	455 mm	L	65 mm		



Test report included!
Prüfbericht inklusive!



- Capacity 1 - 50 l/min
- 1/2" connection in several positions
- High suction lift (8 mtr)
- Standard equipped with Santoprene diaphragms & valves
- Ceramic air-valve system (lubefree)
- Suitable for viscosity liquids >3000 cP
- Max. sizes solid parts in liquid 1,5 mm
- Low noise (72 dBA)
- Pump body: PP
- Suitable for abrasive liquids
- Low air-consumption !
- Dry running capability
- Low maintenance and parts costs
- Bolted (SST) leakage free design
- No Air leakage at liquid stop



Maintenance Free
Ceramic Air-Valve Parts

Wartungsfrei
Lüftungsventilteile aus Keramik

- Kapazität 1 - 50 l/Min.
- Variable 1/2" Anschlüsse
- Hohe Saugleistung (8 m)
- Standardmässig mit Santoprene Membranen und Ventilen ausgestattet
- Keramik-Luft-Ventilsystem (fettfrei)
- Geeignet für viskose Medien >3000 cP
- Feststoffe bis 1,5 mm
- Äusserst leise (72 dBA)
- Pumpengehäuse: PP
- Beständig gegen abrasive Flüssigkeiten
- Geringer Luftverbrauch
- Trockenlauf geeignet
- Niedrige Wartungs- und Ersatzteilkosten
- Bolzen (SST) leckagefreie Ausführung
- Bei Betriebsstopp kein Druckluftverlust

APPLICATIONS

CHEMICALS • SOLVENTS • PLATING • ACIDS • OILS • INKS • GLUES • ALKALIES • ENAMEL
POLYESTER PAINT • WASTE WATER • COOLING LIQUIDS • FOAMS • HYDRAULIC OILS

Flowchart / Flussdiagramm

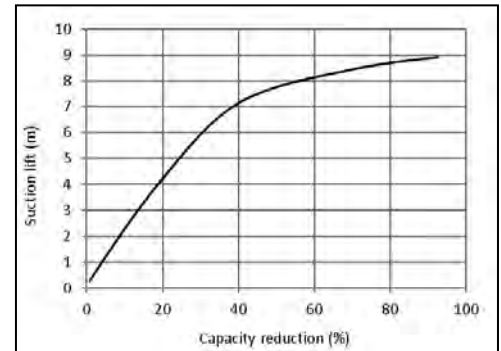
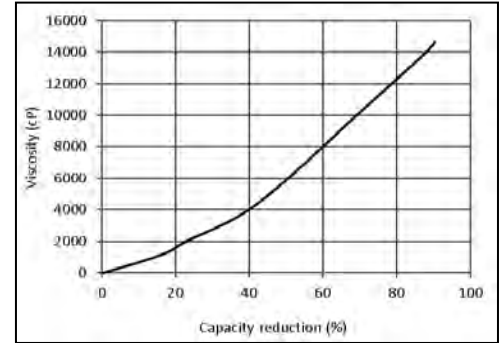
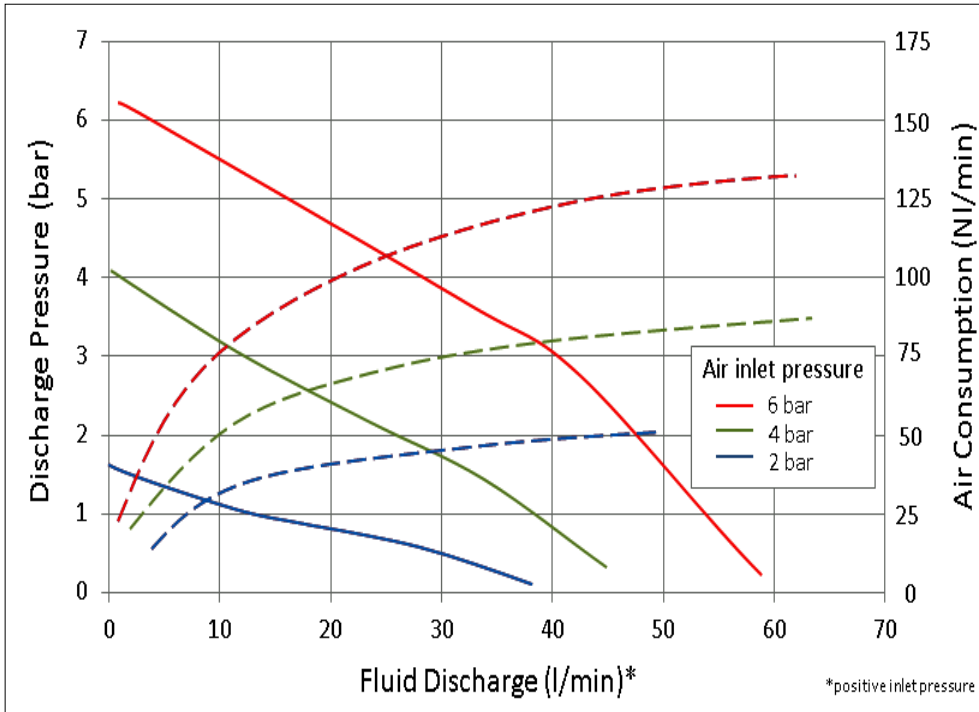

Available types - Verfügbare Typen

Type	liquid wetted parts - lüssigkeitsberührte Teile
TEP50-PX-D	PP / Santoprene
TEP50-PNB-D	PP / NBR
TEP50-PTW-D	PP / PTFE

Air-motor made from Polyacetal (POMC)

Max. weight: 4 Kg

- P** = Polypropylene body
- X** = Santoprene diaphragms & valve balls
- NB** = NBR diaphragms & valve balls
- TW** = Teflon vulcanised diaphragms & teflon valve balls
- D** = Domed shaped diaphragms (extended lifetime!!)

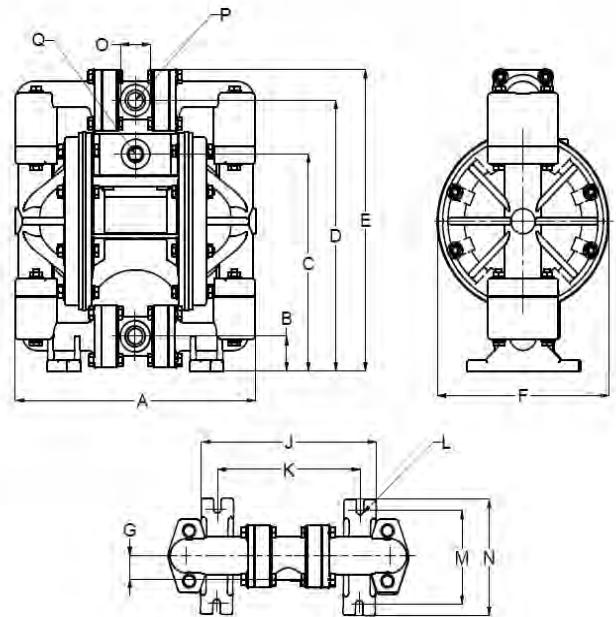

A	224 mm	G	21 mm	O	28 mm
B	31 mm	J	163 mm	P	1/2" female
C	194 mm	K	133 mm	Q	3/8" female
D	242 mm	L	7 mm		
E	270 mm	M	84 mm		
F	160 mm	N	104 mm		



Test report included!
Prüfbericht inklusive!



- Capacity 5 - 100 l/min
- 3/4" connection in several positions
- High suction lift (8,5 mtr)
- Standard equipped with Santoprene diaphragms & valves
- Ceramic air-valve system (lubefree)
- Suitable for viscosity liquids >3000 cP
- Max. sizes solid parts in liquid 3 mm
- Low noise (77 dBa)
- Pump body: PP
- Suitable for abrasive liquids
- Low air-consumption !
- Dry running capability
- Low maintenance and parts costs
- Bolted (SST) leakage free design
- No Air leakage at liquid stop



Maintenance Free
Ceramic Air-Valve Parts

Wartungsfrei
Lüftungsventilteile aus Keramik

- Kapazität 5 - 100 l/Min.
- Variable 3/4" Anschlüsse
- Hohe Saugleistung (8,5 m)
- Standardmässig mit Santoprene Membranen und Ventilen ausgestattet
- Keramik-Luft-Ventilsystem (fettfrei)
- Geeignet für viskose Medien >3000 cP
- Feststoffe bis 3 mm
- Äusserst leise (77 dBa)
- Pumpengehäuse: PP
- Beständig gegen abrasive Flüssigkeiten
- Geringer Luftverbrauch
- Trockenlauf geeignet
- Niedrige Wartungs- und Ersatzteilkosten
- Bolzen (SST) leckagefreie Ausführung
- Bei Betriebsstopp kein Druckluftverlust

APPLICATIONS

CHEMICALS • SOLVENTS • PLATING • ACIDS • OILS • INKS • GLUES • ALKALIES • ENAMEL
POLYESTER PAINT • WASTE WATER • COOLING LIQUIDS • FOAMS • HYDRAULIC OILS

Flowchart / Flussdiagramm

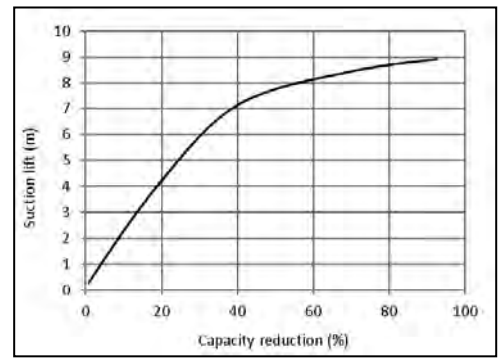
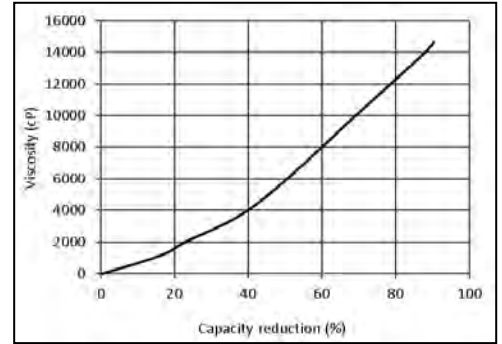
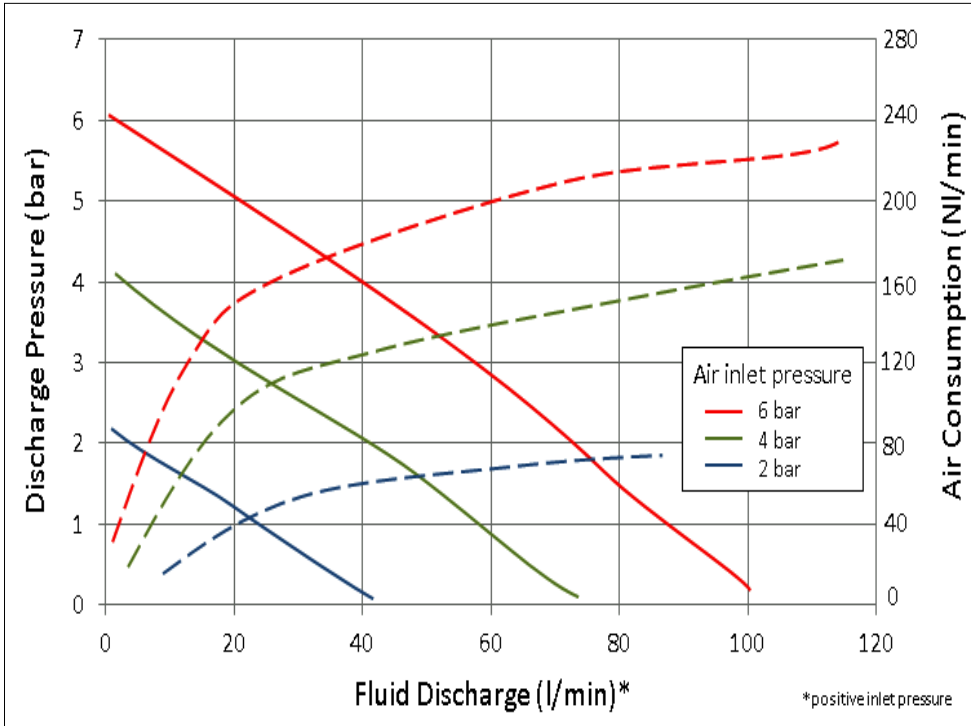

Available types - Verfügbare Typen

Type	liquid wetted parts - Flüssigkeitsberührte Teile
TEP100-PX	PP / Santoprene
TEP100-PNB	PP / NBR
TEP100-PTW	PP / PTFE

Air-motor made from Polyacetal (POMC)

Max. weight: 9 Kg

- P** = Polypropylene body
- X** = Santoprene diaphragms & valve balls
- NB** = NBR diaphragms & valve balls
- TW** = Teflon vulcanised diaphragms & teflon valve balls
- D** = Domed shaped diaphragms (extended lifetime!!)

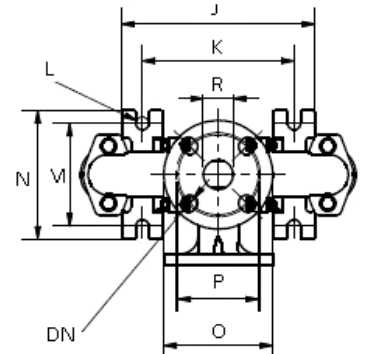
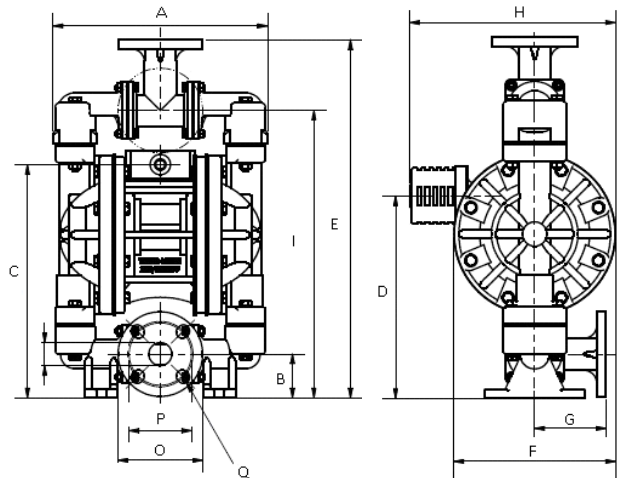

A	279 mm	G	92 mm	M	104 mm
B	57 mm	H	13 mm	N	130 mm
C	329 mm	I	92 mm	Q	3/8" female
D	374 mm	J	194 mm	O	110 mm
E	429 mm	K	154 mm	P	82-85 mm
F	209 mm	L	13 mm	DN	30 mm



Test report included !
Prüfbericht inklusive!



Maintenance Free
Ceramic Air-Valve Parts

Wartungsfrei
Lüftungsventilteile aus Keramik

- Capacity 5 - 130 l/min
- 1" connection in several positions
- High suction lift (8,5 mtr)
- Standard equipped with Santoprene diaphragms & valves
- Ceramic air-valve system (lubefree)
- Suitable for viscosity liquids >3000 cP
- Max. sizes solid parts in liquid 4 mm
- Low noise (77 dBA)
- Pump body: PP
- Suitable for abrasive liquids
- Low air-consumption !
- Dry running capability
- Low maintenance and parts costs
- Bolted (SST) leakage free design
- No Air leakage at liquid stop

- Kapazität 5 - 130 l/Min.
- Variable 1" Anschlüsse
- Hohe Saugleistung (8,5 m)
- Standardmässig mit Santoprene Membranen und Ventilen ausgestattet
- Keramik-Luft-Ventilsystem (fettfrei)
- Geeignet für viskose Medien >3000 cP
- Feststoffe bis 4 mm
- Äusserst leise (77 dBA)
- Pumpengehäuse: PP
- Beständig gegen abrasive Flüssigkeiten
- Geringer Luftverbrauch
- Trockenlauf geeignet
- Niedrige Wartungs- und Ersatzteilkosten
- Bolzen (SST) leckagefreie Ausführung
- Bei Betriebsstopp kein Druckluftverlust

APPLICATIONS

CHEMICALS • SOLVENTS • PLATING • ACIDS • OILS • INKS • GLUES • ALKALIES • ENAMEL
POLYESTER PAINT • WASTE WATER • COOLING LIQUIDS • FOAMS • HYDRAULIC OILS

Flowchart / Flussdiagramm

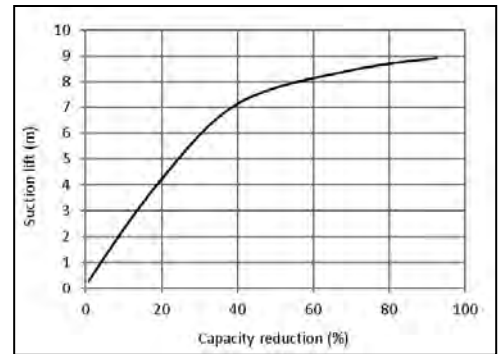
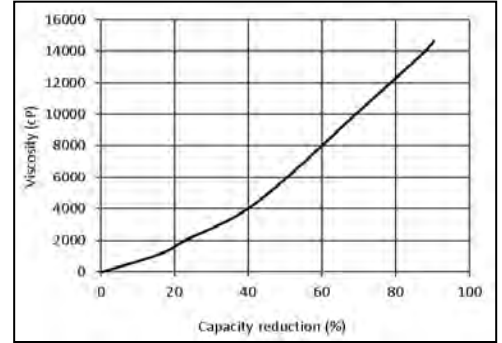
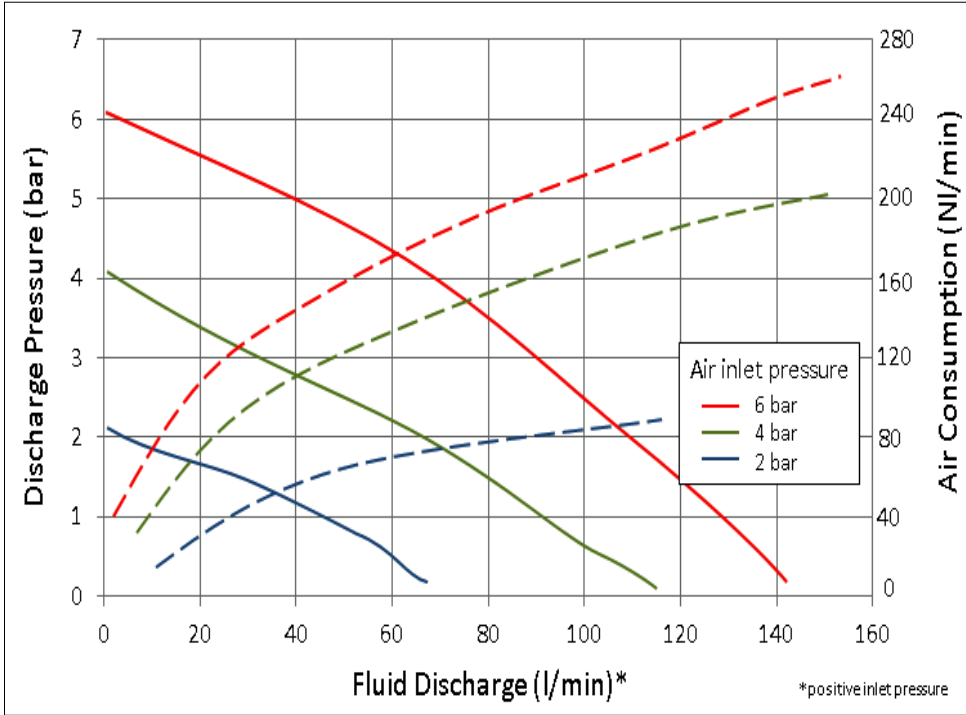

Available types - Verfügbare Typen

Type	liquid wetted parts - Flüssigkeitsberührte Teile
TEP130-PX	PP / Santoprene
TEP130-PNB	PP / NBR
TEP130-PTW	PP / PTFE

Air-motor made from Polyacetal (POMC)

Max. weight: 9 Kg

- P** = Polypropylene body
- X** = Santoprene diaphragms & valve balls
- NB** = NBR diaphragms & valve balls
- TW** = Teflon vulcanised diaphragms & teflon valve balls
- D** = Domed shaped diaphragms (extended lifetime!!)

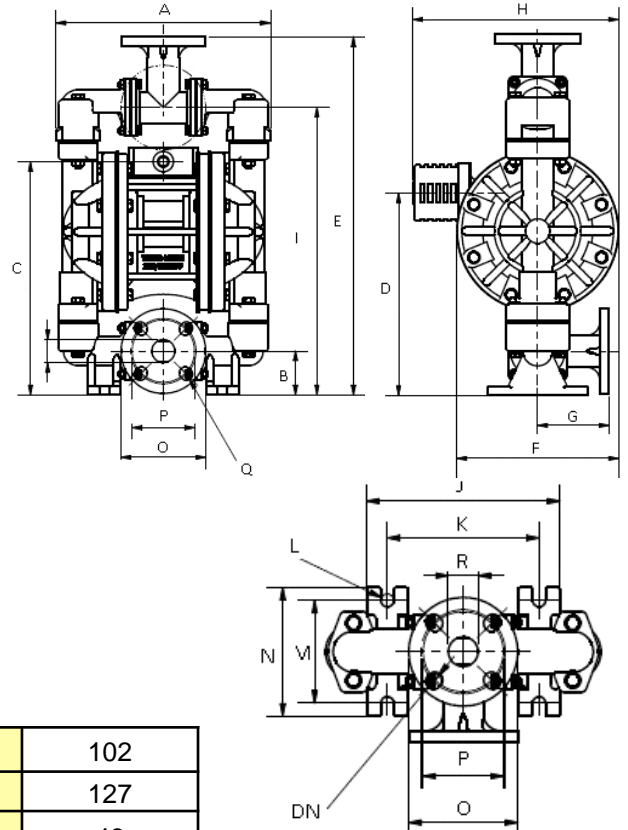

A	305 mm	G	44 mm	M	102
B	32 mm	H	61 mm	N	127
C	313 mm	I	44 mm	O	46
D	359 mm	J	267 mm	P	1" female
E	382 mm	K	219 mm		
F	209 mm	L	13 mm		



Test report included!
Prüfbericht inklusive!



- Capacity 1 - 50 l/min
- 1/2" connection in several positions
- High suction lift (8 mtr)
- Standard equipped with Santoprene diaphragms & valves
- Ceramic air-valve system (lubefree)
- Suitable for viscosity liquids >3000 cP
- Max. sizes solid parts in liquid 1,5 mm
- Low noise (72 dBa)
- Pump body: Alu. (Komaxit coated)
- Suitable for abrasive liquids
- Low air-consumption !
- Dry running capability
- Low maintenance and parts costs
- Bolted (SST) leakage free design
- No Air leakage at liquid stop



Maintenance Free
Ceramic Air-Valve Parts

Wartungsfrei
Lüftungsventilteile aus Keramik

- Kapazität 1 - 50 l/Min.
- Variable 1/2" Anschlüsse
- Hohe Saugleistung (8 m)
- Standardmässig mit Santoprene Membranen und Ventilen ausgestattet
- Keramik-Luft-Ventilsystem (fettfrei)
- Geeignet für viskose Medien >3000 cP
- Feststoffe bis 1,5 mm
- Äusserst leise (72 dBa)
- Pumpengehäuse: Alu. (Komaxit beschichtet)
- Beständig gegen abrasive Flüssigkeiten
- Geringer Luftverbrauch
- Trockenlauf geeignet
- Niedrige Wartungs- und Ersatzteilkosten
- Bolzen (SST) leckagefreie Ausführung
- Bei Betriebsstopp kein Druckluftverlust

APPLICATIONS

CHEMICALS • SOLVENTS • PLATING • ACIDS • OILS • INKS • GLUES • ALKALIES • ENAMEL
POLYESTER PAINT • WASTE WATER • COOLING LIQUIDS • FOAMS • HYDRAULIC OILS

Flowchart / Flussdiagramm

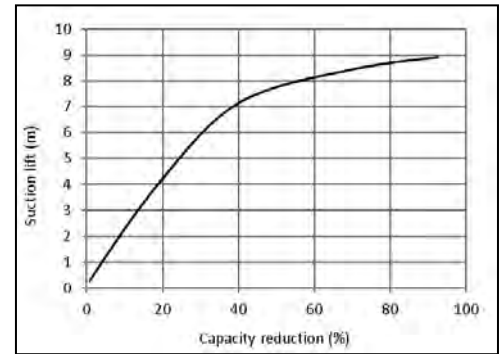
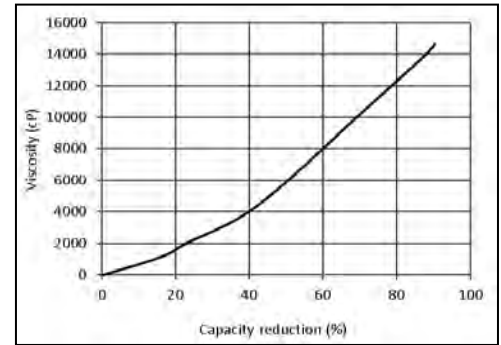
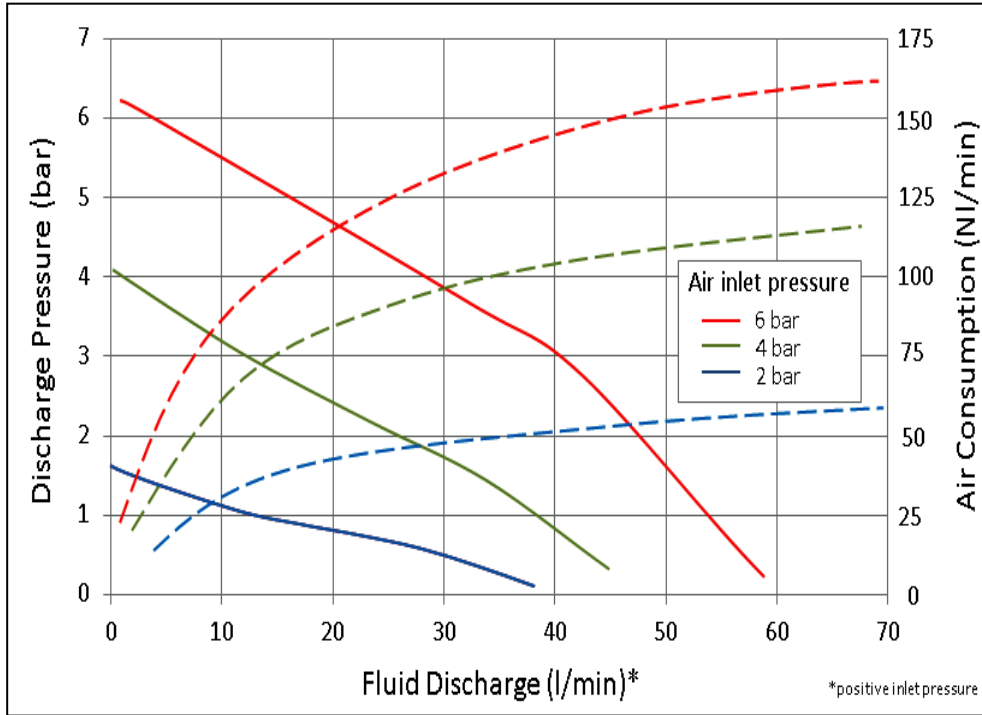

Available types - Verfügbare Typen

Type	liquid wetted parts - Flüssigkeitsberührte Teile
TEP50-AX-D	Alu / Santoprene
TEP50-ANB-D	Alu / NBR
TEP50-ATW-D	Alu / PTFE
Air-motor made from Polyacetal (POMC)	

Max. weight: 5 Kg

- A** = Aluminium body
- X** = Santoprene diaphragms & valve balls
- NB** = NBR diaphragms & valve balls
- TW** = Teflon vulcanised diaphragms & teflon valve balls
- D** = Domed shaped diaphragms (extended lifetime!!)

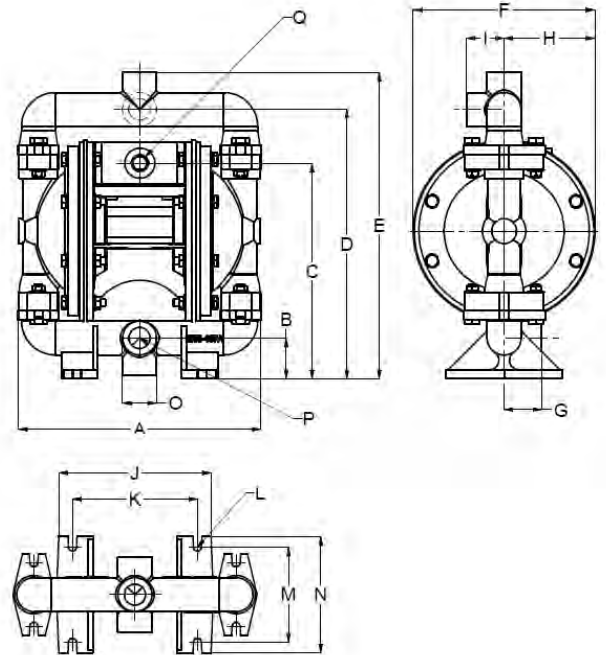

A	213 mm	G	33 mm	M	84
B	36 mm	H	80 mm	N	103
C	191 mm	I	33 mm	O	30
D	238 mm	J	134 mm	P	½" female
E	271 mm	K	110 mm		
F	160 mm	L	7 mm		



Test report included!
Prüfbericht inklusive!



Maintenance Free
Ceramic Air-Valve Parts

Wartungsfrei
Lüftungsventilteile aus Keramik

- Capacity 5 - 130 l/min
- 1" connection in several positions
- High suction lift (8,5 mtr)
- Standard equipped with Santoprene diaphragms & valves
- Ceramic air-valve system (lubefree)
- Suitable for viscosity liquids >3000 cP
- Max. sizes solid parts in liquid 4 mm
- Low noise (77 dBA)
- Pump body: Alu. (Komaxit coated)
- Suitable for abrasive liquids
- Low air-consumption !
- Dry running capability
- Low maintenance and parts costs
- Bolted (SST) leakage free design
- No Air leakage at liquid stop

- Kapazität 5 - 130 l/Min.
- Variable 1" Anschlüsse
- Hohe Saugleistung (8,5 m)
- Standardmässig mit Santoprene Membranen und Ventilen ausgestattet
- Keramik-Luft-Ventilsystem (fettfrei)
- Geeignet für viskose Medien >3000 cP
- Feststoffe bis 4 mm
- Äusserst leise (77 dBA)
- Pumpengehäuse: Alu.(Komaxit beschichtet)
- Beständig gegen abrasive Flüssigkeiten
- Geringer Luftverbrauch
- Trockenlauf geeignet
- Niedrige Wartungs- und Ersatzteilkosten
- Bolzen (SST) leckagefreie Ausführung
- Bei Betriebsstopp kein Druckluftverlust

APPLICATIONS

CHEMICALS • SOLVENTS • PLATING • ACIDS • OILS • INKS • GLUES • ALKALIES • ENAMEL
POLYESTER PAINT • WASTE WATER • COOLING LIQUIDS • FOAMS • HYDRAULIC OILS

Flowchart / Flusdiagramm

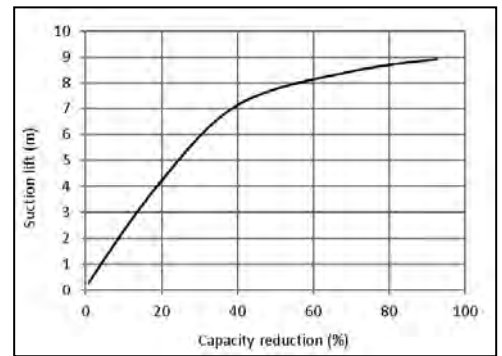
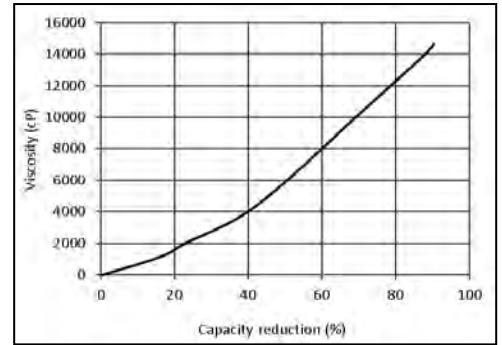
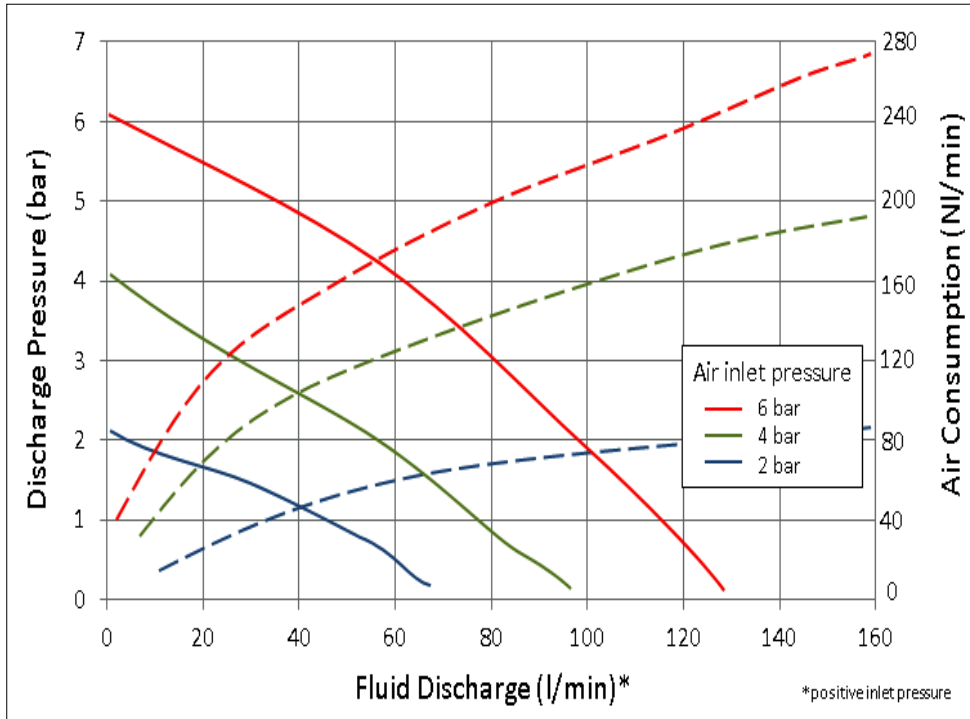

Available types - Verfügbare Typen

Type	liquid wetted parts - Flüssigkeitsberührte Teile
TEP130-AX	Alu / Santoprene
TEP130-ANB	Alu / NBR
TEP130-ATW	Alu / PTFE
Air-motor made from Polyacetal (POMC)	

Max. weight: 12 Kg

- A** = Aluminium body
- X** = Santoprene diaphragms & valve balls
- NB** = NBR diaphragms & valve balls
- TW** = Teflon vulcanised diaphragms & teflon valve balls
- D** = Domed shaped diaphragms (extended lifetime!!)

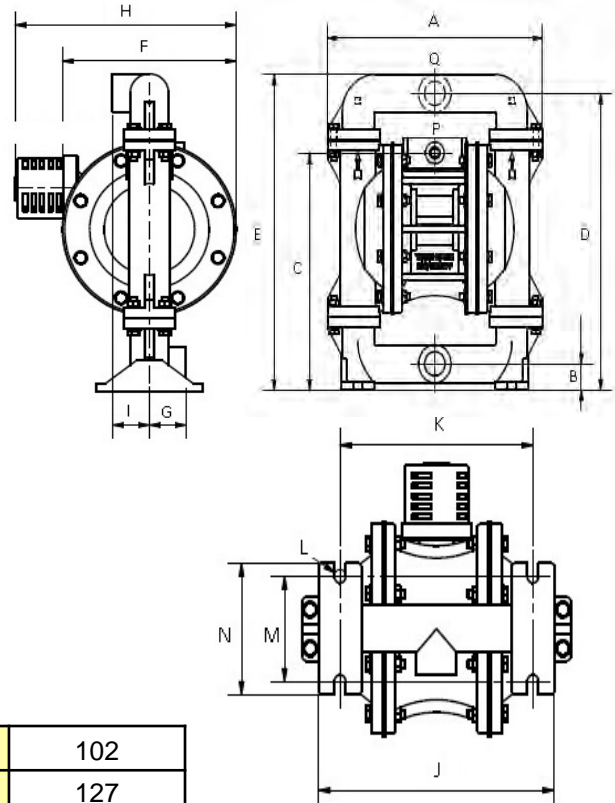

A	305 mm	G	44 mm	M	102
B	32 mm	H	61 mm	N	127
C	313 mm	I	44 mm	O	46
D	359 mm	J	267 mm	P	1" female
E	382 mm	K	219 mm		
F	209 mm	L	13 mm		



Test report included!
Prüfbericht inklusive!



- Capacity 8 - 240 l/min
- 1½" connections
- High suction lift (8,5 mtr)
- Standard equipped with Santoprene diaphragms & valves
- Suitable for viscosity liquids >3000 cP
- Max. sizes solid parts in liquid 5 mm
- Low noise (78 dBA)
- Pump body: Alu. (Komaxit coated)
- Suitable for abrasive liquids
- Low air-consumption !
- Dry running capability
- Low maintenance and parts costs
- Bolted (SST) leakage free design
- No Air leakage at liquid stop

- Kapazität 8 - 240 l/Min.
- 1-1/2" Anschlüsse
- Hohe Saugleistung (8,5 m)
- Standardmässig mit Santoprene Membranen und Ventilen ausgestattet
- Geeignet für viskose Medien >3000 cP
- Feststoffe bis 5 mm
- Äusserst leise (78 dBA)
- Pumpengehäuse: Alu. (Komaxit beschichtet)
- Beständig gegen abrasive Flüssigkeiten
- Geringer Luftverbrauch
- Trockenlauf geeignet
- Niedrige Wartungs- und Ersatzteilkosten
- Bolzen (SST) leakagefrei Ausführung
- Bei Betriebsstopp kein Druckluftverlust

APPLICATIONS

CHEMICALS • SOLVENTS • PLATING • ACIDS • OILS • INKS • GLUES • ALKALIES • ENAMEL
POLYESTER PAINT • WASTE WATER • COOLING LIQUIDS • FOAMS • HYDRAULIC OILS

Flowchart / Flussdiagramm

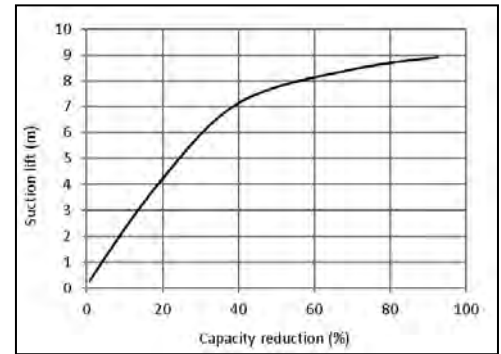
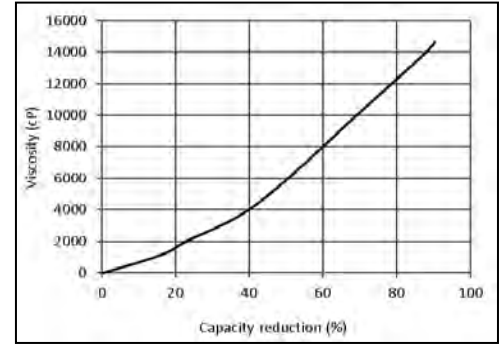
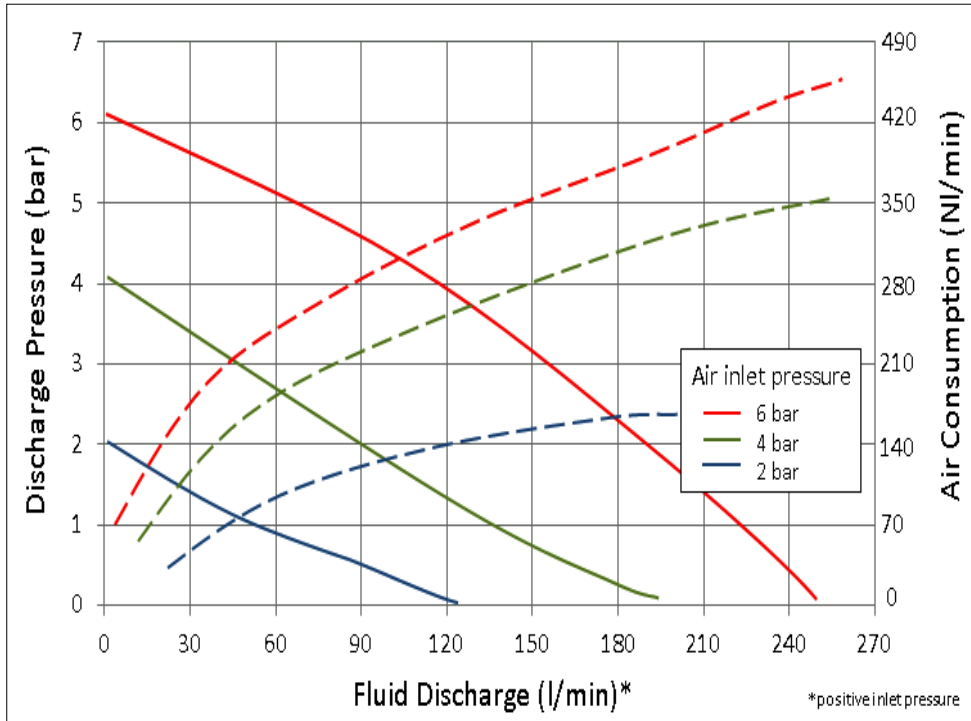

Available types - Verfügbare Typen

Type	liquid wetted parts - Flüssigkeitsberührte Teile
T240-AX-D	Alu / Santoprene
T240-ANB-D	Alu / NBR
T240-ATW	Alu / PTFE

Max. weight: 18 Kg

- A** = Aluminium body
- X** = Santoprene diaphragms & valve balls
- NB** = NBR diaphragms & valve balls
- TW** = Teflon vulcanised diaphragms & teflon valve balls
- D** = Domed shaped diaphragms (extended lifetime!!)

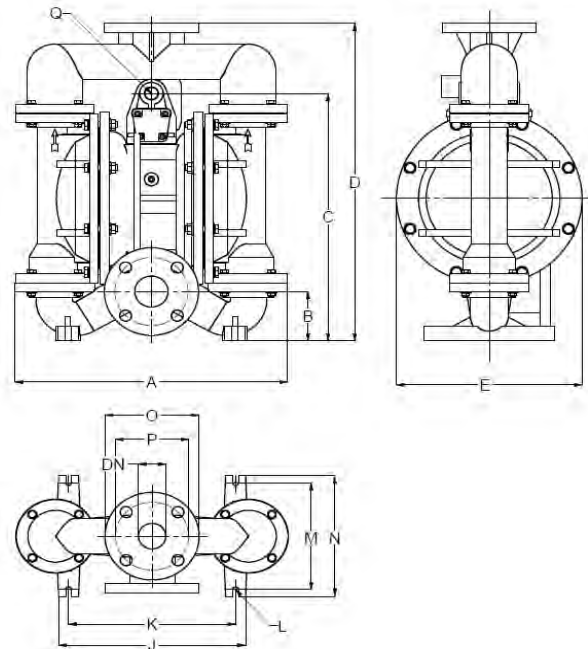

A	367 mm	J	252 mm	O	127 mm
B	71 mm	K	225 mm	P	99 mm
C	358 mm	L	8 mm	DN	45 mm
D	460 mm	M	155 mm		
E	250 mm	N	175 mm		
H	209 mm	Q	3/8" female		



Test report included!
Prüfbericht inklusive!



- Capacity 10 - 530 l/min
- 2" connections
- High suction lift (8,5 mtr)
- Standard equipped with Santoprene diaphragms & valves
- Suitable for viscosity liquids >3000 cP
- Max. sizes solid parts in liquid 6,5 mm
- Low noise (75 dBA)
- Pump body: Alu. (Komaxit coated)
- Suitable for abrasive liquids
- Low air-consumption !
- Dry running capability
- Low maintenance and parts costs
- Bolted (SST) leakage free design
- No Air leakage at liquid stop

- Kapazität 10 - 530 l/Min.
- Variable 2" Anschlüsse
- Hohe Saugleistung (8,5 m)
- Standardmässig mit Santoprene Membranen und Ventilen ausgestattet
- Geeignet für viskose Medien >3000 cP
- Feststoffe bis 6,5 mm
- Äusserst leise (75 dBA)
- Pumpengehäuse: Alu.(Komaxit beschichtet)
- Beständig gegen abrasive Flüssigkeiten
- Geringer Luftverbrauch
- Trockenlauf geeignet
- Niedrige Wartungs- und Ersatzteilkosten
- Bolzen (SST) leckagefreie Ausführung
- Bei Betriebsstopp kein Druckluftverlust

APPLICATIONS

CHEMICALS • SOLVENTS • PLATING • ACIDS • OILS • INKS • GLUES • ALKALIES • ENAMEL
POLYESTER PAINT • WASTE WATER • COOLING LIQUIDS • FOAMS • HYDRAULIC OILS

Flowchart / Flussdiagramm

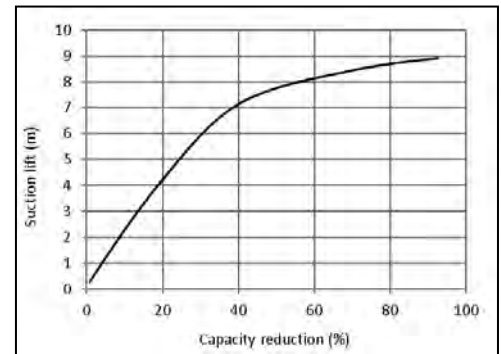
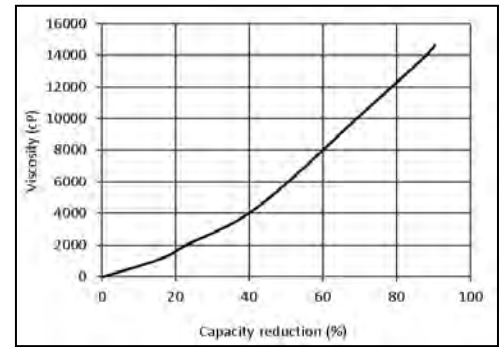
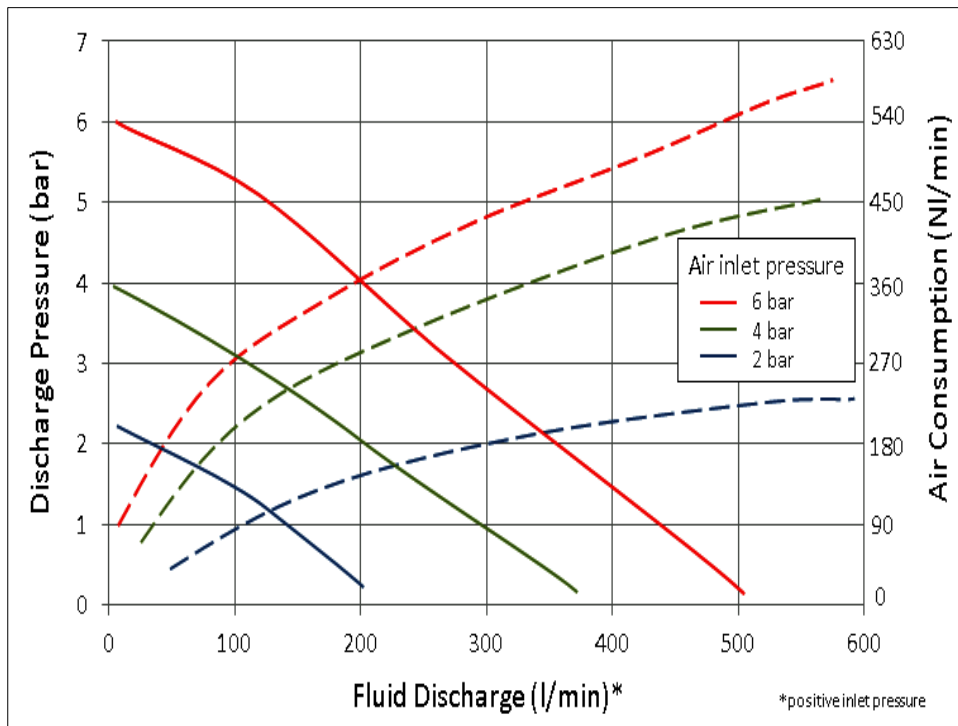

Available types - Verfügbare Typen

Type	liquid wetted parts - Flüssigkeitsberührte Teile
T530-AX-D	Alu / Santoprene
T530-ANB-D	Alu / NBR
T530-ATW	Alu / PTFE

Max. weight: 35 Kg

- A** = Aluminium body
- X** = Santoprene diaphragms & valve balls
- NB** = NBR diaphragms & valve balls
- TW** = Teflon vulcanised diaphragms & teflon valve balls
- D** = Domed shaped diaphragms (extended lifetime!!)

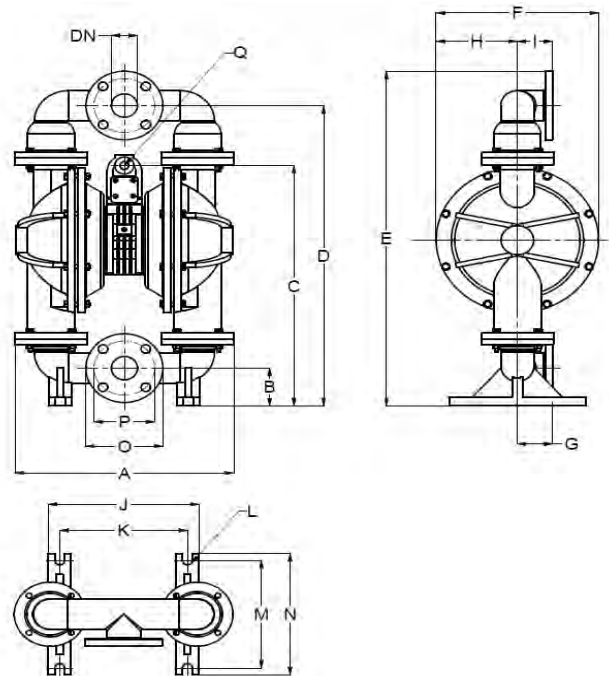

A	435 mm	G	70 mm	M	240 mm
B	84 mm	H	162 mm	N	270 mm
C	535 mm	I	70 mm	Q	½" female
D	669 mm	J	299 mm	O	153 mm
E	746 mm	K	254 mm	P	121 mm
F	323 mm	L	20 mm	DN	52 mm



Test report included!
Prüfbericht inklusive!



- Capacity 10 - 980 l/min
- 3" connections
- High suction vacuum (8,5 mtr)
- Standard equipped with Santoprene diaphragms & valves
- Suitable for viscosity liquids >3000 cP
- Max. sizes solid parts in liquid 10 mm
- Low noise (68 dBA)
- Pump body: Alu. (Komaxit coated)
- Suitable for abrasive liquids
- Low air-consumption !
- Dry running capability
- Low maintenance and parts costs
- Bolted (SST) leakage free design
- No Air leakage at liquid stop

- Kapazität 10 - 980 l/Min.
- 3" Anschlüsse
- Hohe Saugleistung (8,5 m)
- Standardmässig mit Santoprene Membranen und Ventilen ausgestattet
- Geeignet für viskose Medien >3000 cP
- Feststoffe bis 10 mm
- Äusserst leise (68 dBA)
- Pumpengehäuse: Alu.(Komaxit beschichtet)
- Beständig gegen abrasive Flüssigkeiten
- Geringer Luftverbrauch
- Trockenlauf geeignet
- Niedrige Wartungs- und Ersatzteilkosten
- Bolzen (SST) leckagefreie Ausführung
- Bei Betriebsstopp kein Druckluftverlust

APPLICATIONS

CHEMICALS • SOLVENTS • PLATING • ACIDS • OILS • INKS • GLUES • ALKALIES • ENAMEL
POLYESTER PAINT • WASTE WATER • COOLING LIQUIDS • FOAMS • HYDRAULIC OILS

Flowchart / Flussdiagramm

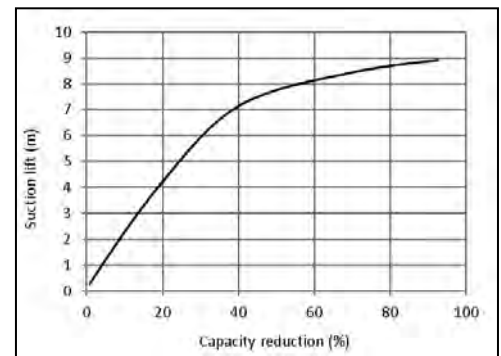
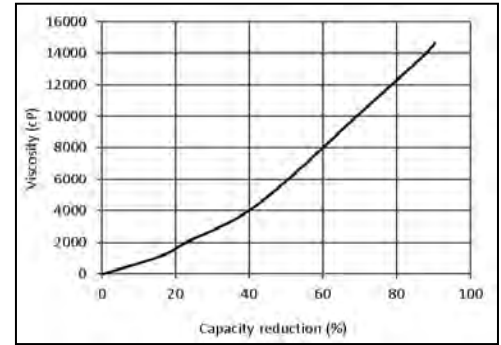
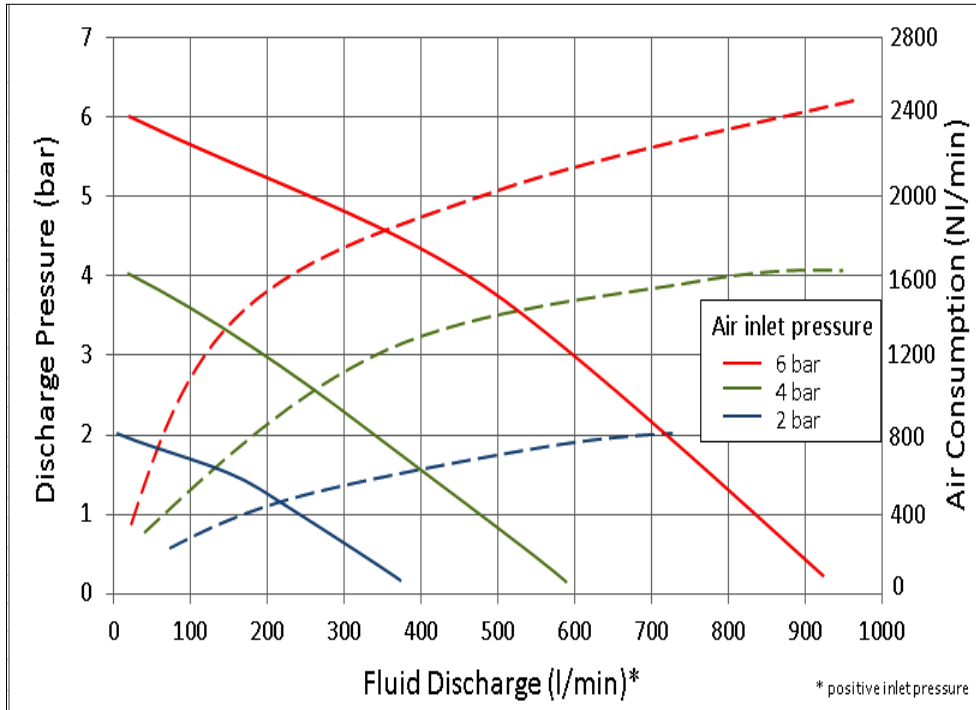

Available types - Verfügbare Typen

Type	liquid wetted parts - Flüssigkeitsberührte Teile
T980-AX-D	Alu / Santoprene
T980-ANB-D	Alu / NBR
T980-ATW-D	Alu / PTFE

Max. weight: 70 Kg

- A** = Aluminium body
- X** = Santoprene diaphragms & valve balls
- NB** = NBR diaphragms & valve balls
- TW** = Teflon vulcanised diaphragms & teflon valve balls
- D** = Domed shaped diaphragms (extended lifetime!!)

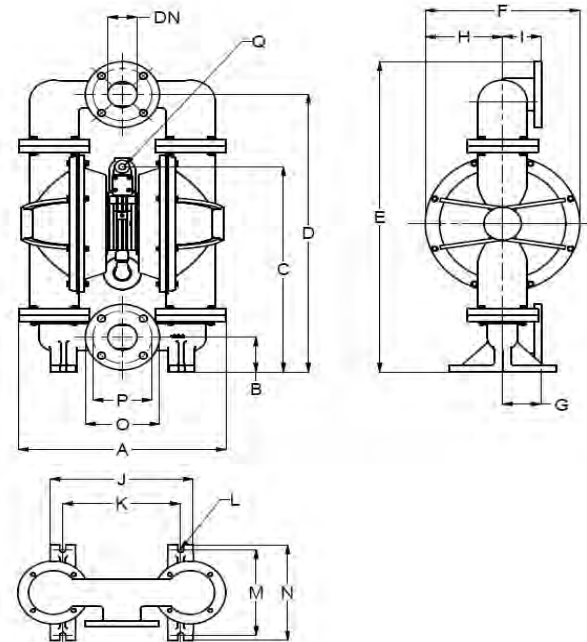

A	538 mm	G	100 mm	M	249 mm
B	102 mm	H	200 mm	N	278 mm
C	600 mm	I	100 mm	Q	½" female
D	811 mm	J	370 mm	O	192 mm
E	907 mm	K	305 mm	P	153 mm
F	400 mm	L	15 mm	DN	76 mm



Test report included!
Prüfbericht inklusive!



- Capacity 5 - 130 l/min
- 1" connection in several positions
- High suction lift (8,5 mtr)
- Standard equipped with Santoprene diaphragms & valves
- Ceramic air-valve system (lubefree)
- Suitable for viscosity liquids >3000 cP
- Max. sizes solid parts in liquid 4 mm
- Low noise (77 dBA)
- Pump body: Stainless Steel
- Suitable for abrasive liquids
- Low air-consumption !
- Dry running capability
- Low maintenance and parts costs
- Bolted (SST) leakage free design
- No Air leakage at liquid stop



Maintenance Free
Ceramic Air-Valve Parts

Wartungsfrei
Lüftungsventilteile aus Keramik

- Kapazität 5 - 130 l/Min.
- Variable 1" Anschlüsse
- Hohe Saugleistung (8,5 m)
- Standardmässig mit Santoprene Membranen und Ventilen ausgestattet
- Keramik-Luft-Ventilsystem (fettfrei)
- Geeignet für viskose Medien >3000 cP
- Feststoffe bis 4 mm
- Äusserst leise (77 dBA)
- Pumpengehäuse: Edelstahl
- Beständig gegen abrasive Flüssigkeiten
- Geringer Luftverbrauch
- Trockenlauf geeignet
- Niedrige Wartungs- und Ersatzteilkosten
- Bolzen (SST) leckagefreie Ausführung
- Bei Betriebsstopp kein Druckluftverlust

APPLICATIONS

CHEMICALS • SOLVENTS • PLATING • ACIDS • OILS • INKS • GLUES • ALKALIES • ENAMEL
POLYESTER PAINT • WASTE WATER • COOLING LIQUIDS • FOAMS • HYDRAULIC OILS

Flowchart / Flussdiagramm

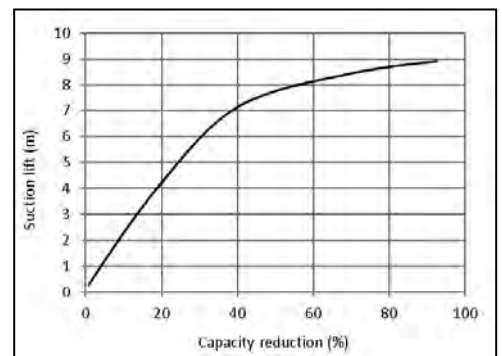
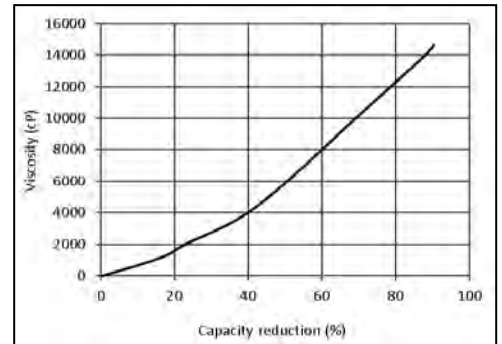
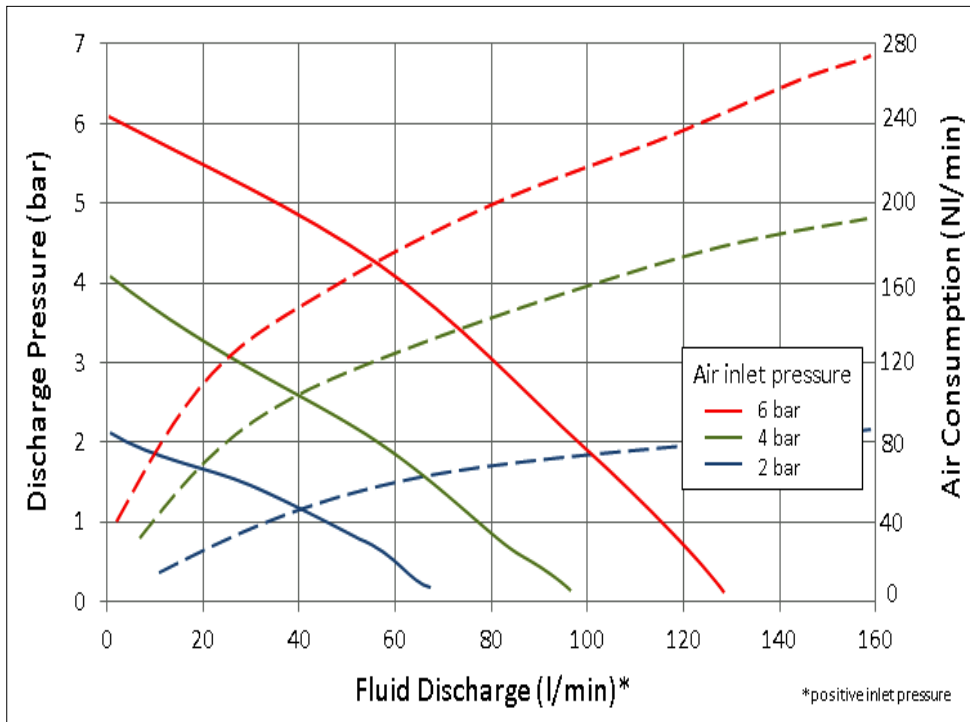

Available types - Verfügbare Typen

Type	liquid wetted parts - Flüssigkeitsberührte Teile
TEP130-SX	St. Steel / Santoprene
TEP130-SNB	St. Steel / NBR
TEP130-STW	St. Steel / PTFE

Air-motor made from Pro-opiomelanocortin (POMC)

Max. weight: 18 Kg

- S** = Stainless steel body
- X** = Santoprene diaphragms & valve balls
- NB** = NBR diaphragms & valve balls
- TW** = Teflon vulcanised diaphragms & teflon valve balls
- D** = Domed shaped diaphragms (extended lifetime!!)

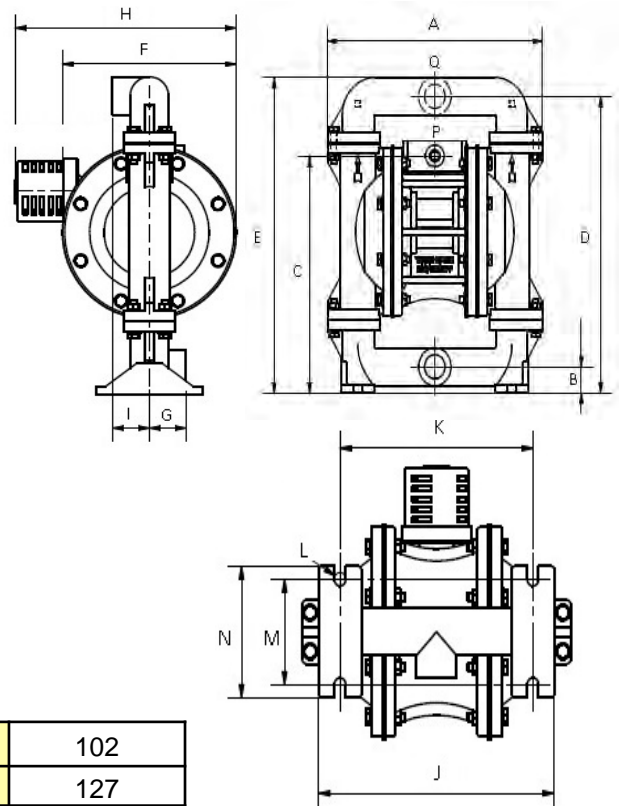

A	305 mm	G	44 mm	M	102
B	32 mm	H	61 mm	N	127
C	313 mm	I	44 mm	O	46
D	359 mm	J	267 mm	P	1" female
E	382 mm	K	219 mm		
F	209 mm	L	13 mm		



Test report included!
Prüfbericht inklusive!



- Capacity 10 - 530 l/min
- 2" connections
- High suction lift (8,5 mtr)
- Standard equipped with Santoprene diaphragms & valves
- Suitable for viscosity liquids >3000 cP
- Max. sizes solid parts in liquid 6,5 mm
- Low noise (75 dBA)
- Pump body: Stainless Steel
- Suitable for abrasive liquids
- Low air-consumption !
- Dry running capability
- Low maintenance and parts costs
- Bolted (SST) leakage free design
- No Air leakage at liquid stop

- Kapazität 10 - 530 l/Min.
- Variable 2" Anschlüsse
- Hohe Saugleistung (8,5 m)
- Standardmässig mit Santoprene Membranen und Ventilen ausgestattet
- Geeignet für viskose Medien >3000 cP
- Feststoffe bis 6,5 mm
- Äusserst leise (75 dBA)
- Pumpengehäuse: Edelstahl
- Beständig gegen abrasive Flüssigkeiten
- Geringer Luftverbrauch
- Trockenlauf geeignet
- Niedrige Wartungs- und Ersatzteilkosten
- Bolzen (SST) leckagefreie Ausführung
- Bei Betriebsstopp kein Druckluftverlust

APPLICATIONS

CHEMICALS • SOLVENTS • PLATING • ACIDS • OILS • INKS • GLUES • ALKALIES • ENAMEL
POLYESTER PAINT • WASTE WATER • COOLING LIQUIDS • FOAMS • HYDRAULIC OILS

Flowchart / Flussdiagramm

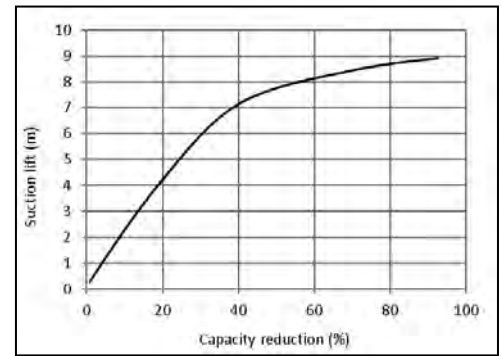
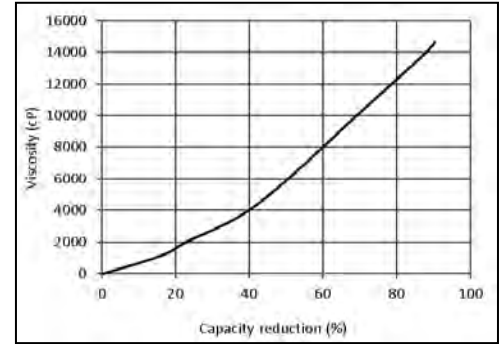
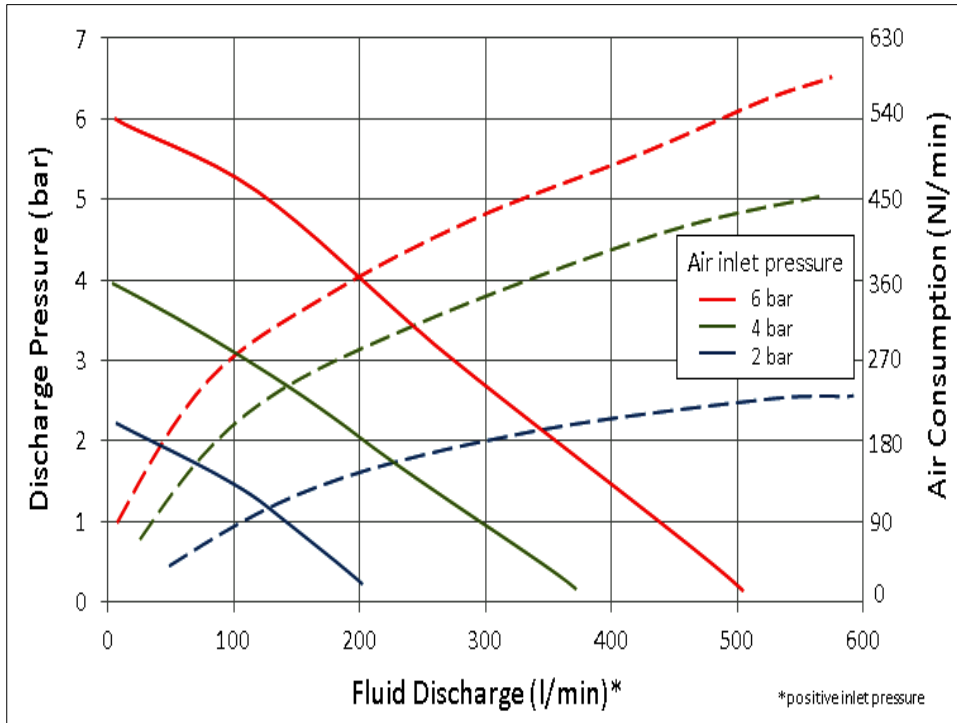

Available types - Verfügbare Typen

Type	liquid wetted parts - Flüssigkeitsberührte Teile
TES530-SX-D	St. steel / Santoprene
TES530-SNB-D	St. steel / NBR
TES530-STW	St. steel / PTFE

Max. weight: 70 Kg

- S** = Stainless steel body
- X** = Santoprene diaphragms & valve balls
- NB** = NBR diaphragms & valve balls
- TW** = Teflon vulcanised diaphragms & teflon valve balls
- D** = Domed shaped diaphragms (extended lifetime!!)

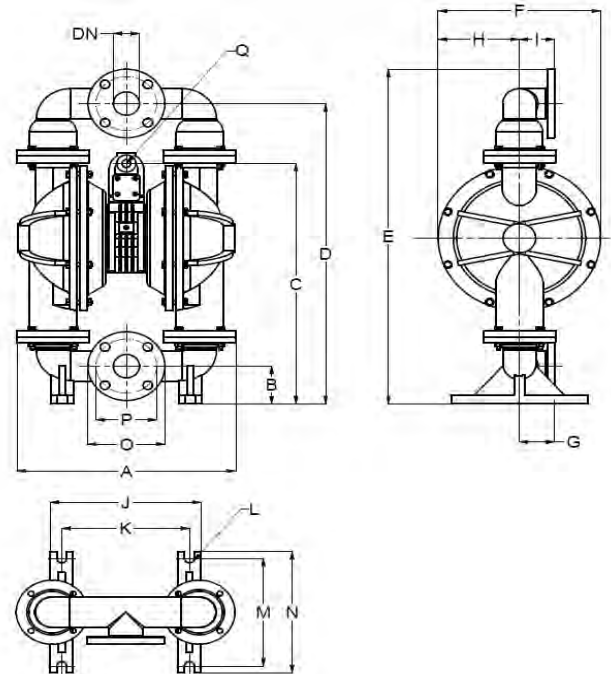

A	435 mm	G	70 mm	M	240 mm
B	84 mm	H	162 mm	N	270 mm
C	535 mm	I	70 mm	Q	½" female
D	669 mm	J	299 mm	O	153 mm
E	746 mm	K	254 mm	P	121 mm
F	323 mm	L	20 mm	DN	52 mm

SIWATEC, a.s.

Dalimilova 285/54
783 35 Olomouc
Czech Republic
Tel. +420 585 229 130

cerpadla@siwatec.cz
www.siwatec.cz

For more information about our worldwide locations, approvals, certifications, and local representatives, please visit www.tecnomaticpump.com. Tecno-Matic Europe BV reserves the right to incorporate our latest design and material changes without notice or obligation. Design features, materials of construction and dimensional data, as described in this bulletin, are provided for your information only and should not be relied upon unless confirmed in writing.

Certified drawings are available upon request.